

Technical Guideline:

The Use of Modified Bituminous Binders in Road Construction

TG1 Fourth Edition January 2019



excellence in bituminous products

Published by
Southern African Bitumen Association (Sabita)

Postnet Suite 56, Private Bag X21

Howard Place, 7450, South Africa

Tel: +27 21 531 2718

Fax: +27 21 531 2606

Email: info@sabita.co.za

First published in 2001

ISBN 978-1-874968-74-0

Copyright © 2019 Sabita

DISCLAIMER

Considerable effort has been made to ensure the accuracy and reliability of the information contained in this publication. However, neither Sabita nor any of its members can accept liability for any loss, damage or injury whatsoever resulting from the use of this information. The content of this publication does not necessarily represent the views of any members of Sabita.

Copyright notice: This document and the contents of these pages are the Southern African Bitumen Association (Sabita). This document is made available to Members of Sabita as a service and is intended for the sole use of such Members, who may reproduce this document in whole or in part for the purpose of implementation of the systems described herein. All other rights are reserved. Any other use requires the prior written permission of Sabita.

Technical Guideline:

**The use of modified bituminous
binders in road construction**

**TG 1 Fourth Edition
January 2019**

Published by Sabita
Postnet Suite 56
Private Bag X21
Howard Place 7450
South Africa

ISBN 978-1-874968-74-0

MANUALS PUBLISHED BY SABITA

Manual 1	Technical guidelines: Construction of bitumen rubber seals
Manual 2	Bituminous binders for road construction and maintenance
Manual 3	(Withdrawn)
Manual 4	(Withdrawn)
Manual 5	Guidelines for the manufacture and construction of hot mix asphalt
Manual 6	(Withdrawn)
Manual 7	SurperSurf – Economic warrants for surfacing roads
Manual 8	Guidelines for the safe and responsible handling of bituminous products
Manual 9	(Withdrawn)
Manual 10	Bituminous surfacing for low volume roads and temporary deviations
Manual 11	(Withdrawn)
Manual 12	Labour Absorptive methods in road construction using bituminous materials
Manual 13	LAMBs – The design and use of large aggregate mixes for bases
Manual 14	(Superseded by TG2)
Manual 15	(Withdrawn)
Manual 16	(Withdrawn)
Manual 17	Porous asphalt mixes: Design and use
Manual 18	Appropriate standards for the use of sand asphalt
Manual 19	Guidelines for the design, manufacture and construction of bitumen rubber asphalt wearing courses
Manual 20	Sealing of active cracks in road pavements
Manual 21	(Superseded by TG2)
Manual 22	Hot mix paving in adverse weather
Manual 23	Code of practice: Loading bitumen at refineries
Manual 24	(Withdrawn)
Manual 25	Code of practice: Transportation, off-loading and storage of bitumen and bituminous products
Manual 26	Interim guidelines for primes and stone pre-coating fluids
Manual 27	Guidelines for thin hot mix asphalt wearing courses on residential streets
Manual 28	Best practice for the design and construction of slurry seals
Manual 29	Guide to the safe use of solvents in a bituminous products laboratory
Manual 30	A guide to the selection of bituminous binders for road construction
Manual 31	Guidelines for calibrating a binder distributor to ensure satisfactory performance
Manual 32	Best practice guideline and specification for warm mix asphalt
Manual 33	Design procedure for high modulus asphalt (EME)
Manual 34	(A) Guidelines to the transportation of bitumen and (B) Bitumen spill protocol (booklets)
Manual 35/TRH8	Design and use of Asphalt in Road Pavements

TECHNICAL GUIDELINES

**TG 1 The use of modified binders in road
Construction**

TG 2 Bitumen stabilised materials

TG3 Asphalt reinforcement for road condition

SABITA DVD SERIES

DVD100	Test methods for bituminous products
DVD200	Training guide for the construction and repair of bituminous surfacing by hand
DVD300	Manufacture, paving and compaction of hot mix asphalt
DVD410	The safe handling of bitumen
DVD420	Treatment of bitumen burns
DVD430	Working safely with bitumen
DVD440	Firefighting in the bituminous products industry
DVD450	Safe loading and off-loading of bitumen

PREFACE

The publication of the first edition of Technical Guideline No. 1 (TG1): *The use of Modified Bituminous Binders in Road Construction* in 2001 was a major step towards achieving a unified approach to the specification and use of modified binders in South Africa. The classification of modified binders into various generic classes which are, to some extent, “polymer blind”, is now firmly entrenched in the industry.

Since that time the modification of bituminous binders has become an increasingly more dynamic field. In addition, new modifiers, including rejuvenators and warm-mix technology, have been introduced into the road construction sector and are being specified on a more regular basis. As a result, in 2005, the Road Pavements Forum (RPF) reconstituted a task group with a mandate to review the current edition of TG1 and to revise the document to reflect the improved knowledge obtained in promoting current industry best-practice. The activities of this task group culminated in revised publications in 2007 and 2015.

Since 2015 considerable progress has been made in South Africa on the transition to a performance grade (PG) specification for bituminous binders with the publication in 2018 of a SABS technical specification (SATS 3208). The intention is to implement this specification on a trial basis for two years. Nevertheless, the use of this technical guideline – which presents an empirical approach to tests and compliance limits – is likely to continue during the transition period until the replacement of the current binder specification (SANS 4001-BT1) with one that offers the opportunity to select binders on their performance characteristics, rather than the type and proportion of modifier employed.

Against this background it was decided to update this document to take account of developments in the bitumen-rubber sector where new products with reduced storage and handling temperatures and improved shelf life and rheological properties have been introduced and need to be considered for use in the appropriate applications.

While the requirements and/or limitations as recommended in this document should serve the purpose in the majority of applications of these products, it is accepted that specifying agencies with adequate experience may prescribe other limits based on their own specific circumstances, environment and experience.

ACKNOWLEDGMENTS

On behalf of the road construction industry represented by the RPF, Sabita acknowledges, with thanks, the time and effort given by the following members of the Task Group responsible for compiling this important guideline document for the industry:

Dennis Rossmann	SANRAL (Chair)
Riaan Burger	SANRAL
Simon Coe	Chevron SA (Pty) Ltd
Anton Ferreira	Sabita
Joe Grobler	SMEC SA (Pty) Ltd
Bob Hornsey	Shell SA Marketing (Pty) Ltd
Kim Jenkins	University of Stellenbosch
Morné Labuschagne	Colas SA (Pty) Ltd
Hannes Lambert	Tosas (Pty) Ltd
Caroline Lawson	Bituguard Southern Africa
Hennie Loots	Specialised Road Technologies (Pty) Ltd
Kobus Louw	Colas SA (Pty) Ltd
Chumisa Loyilane	South African Bureau of Standards
Herman Marais	Much Asphalt (Pty) Ltd
Georges Mturi	CSIR
Johan Muller	Tosas (Pty) Ltd
Piet Myburgh	
Krishna Naidoo	eThekweni Municipality
Wynand Nortje	National Asphalt (Pty) Ltd
Richard Ntombela	DuPont de Nemours SA (Pty) Ltd
Piet Roets	Sasol Technology Fuels Research
Sibongiseni Shabalala	Sasol Technology Fuels Research
Saied Solomons	Sabita
Roy Stanley	Tarspray cc
Jacques van Heerden	Tosas (Pty) Ltd
Benoit Verhaeghe	CSIR
Dickie Werner	Tosas (Pty) Ltd
Carl Williams	Emergeco Trading (Pty) Ltd

Some of the aspects incorporated into the original document were based on guidelines developed by Austroads and the Australian Asphalt Paving Association (AAPA). Their permission to do so is gratefully acknowledged.

SCOPE

This technical guideline covers the requirements for generic classes of homogeneous (thermoplastic polymers) and non-homogeneous (bitumen-rubber) modified binders for use in asphalt, surface seals and crack sealing applications. It includes recommendations related to the appropriate selection criteria, product property requirements, HSE, manufacture, storage, handling and quality control measures for the procurement and application of modified binders.

Methods for the sampling, preparation and common test procedures of these products have been included as an Appendix to the document. The intention is that most of these tests will be incorporated into the South African National Standards (SANS) standard test methods for compliance with South African National Accreditation Systems (SANAS) requirements. This process is already well under way.

It should be noted that aggregate selection, mix design and final product composition are not addressed here. It is recommended that practitioners refer to the relevant manuals/guidelines, or appropriate research, covering these aspects. However, the scope of this document has been extended to include requirements for special applications related to fuel resistance, bond coats and microsurfacing. These were not previously covered under the generic specification framework.

Furthermore a protocol for conducting a field evaluation for introducing new modified binder products is also provided as a guideline in the appendices. While the scope of this document is, as stated above, confined to generic classes of modified binders, the existence of proprietary products, offering enhanced performance characteristics, is acknowledged. It is expected that the manufacturers or marketers of such products would follow a certification process such as *Agrément South Africa*, which could include the provision of appropriate performance guarantees.

Contents

1.	INTRODUCTION	8
2.	OCCUPATIONAL HEALTH, SAFETY AND THE ENVIRONMENT (HSE)	10
2.1	Safety hazards	10
2.1.1	Elevated temperature	10
2.1.2	Flammable vapour and ignition sources	10
2.1.3	Reactive bitumen foaming ('boil over')	10
2.1.4	Controlling the safety hazards	10
2.2	Health hazards.....	11
2.2.1	Terminology – vapour and fumes	11
2.2.2	Potential health hazards and effects of modified bitumen	11
2.2.3	Increased likelihood of exposure to harmful fumes during handling and application of modified bitumen.....	11
2.2.4	Controlling the health hazards	11
2.3	Environmental aspects	12
2.3.1	12
2.3.2	Air emissions	12
2.4	Literature.....	12
3.	COMPOSITION AND CHARACTERISTICS	14
3.1	Composition of bitumen modifiers	14
3.1.1	Homogeneous binders	15
3.1.2	Non-homogeneous binders.....	17
3.1.3	Naturally occurring hydrocarbon modifiers.....	18
3.1.4	High molecular weight waxes	19
3.1.5	Polymer modified bitumen emulsions	19
3.2	Behavioural characteristics	20
3.2.1	Rheology (flow behaviour)	20
3.2.2	Elasticity	21
3.2.3	Cohesion.....	21
3.2.4	Adhesion.....	22
3.2.5	Ageing and durability	23
3.3	Use of cutters	24
3.3.1	Factors affecting the cutting back of modified binders	24
4.	Manufacture.....	27
4.1	General	27
4.2	Homogenous binders	28

4.2.1 SBR modified bitumen.....	28
4.2.2 SBS modified bitumen.....	28
4.2.3 RET.....	28
4.2.4 EVA.....	28
4.2.5 Hydrocarbon modified binders and high molecular weight waxes.....	29
4.3 Non-homogenous polymer modified binder.....	29
4.3.1 The wet method.....	29
4.3.2 The dry method.....	30
4.4 General items.....	30
4.4.1 Combining agents.....	30
4.4.2 Pre-blending.....	30
4.4.3 Mixing.....	30
4.4.4 High shear mixers.....	30
5. MODIFIED BINDER CLASSIFICATION.....	31
6. PRODUCT REQUIREMENTS.....	33
6.1 Special applications.....	36
6.1.1 Modified emulsions for microsurfacing.....	36
6.1.2 Hydrocarbon modified bitumen for high modulus asphalt.....	37
6.1.3 Modified binders for fuel resistant surfacings.....	37
6.1.4 Modified bitumen emulsion for tack coat.....	37
6.1.5 Modified emulsions for geotextile application.....	38
7. SELECTION CRITERIA.....	39
7.1 Spray Seal Applications.....	40
7.1.1 Environmental influences during application.....	40
7.1.2 Aggregate influences.....	41
7.1.3 Substrate influences.....	41
7.1.4 Project location and programming influences.....	42
7.1.5 Traffic influences.....	43
7.1.6 Design influences.....	44
7.1.7 Selection guide.....	44
7.2 Asphalt.....	44
7.2.1 Hot mix asphalt.....	44
7.2.2 Warm mix asphalt.....	47
8. CONSTRUCTION.....	49
8.1 Introduction.....	49
8.2 Construction procedures.....	49

9. QUALITY ASSURANCE DURING STORAGE AND HANDLING	53
9.1 Heating of modified binders	53
9.1.1 Hot-applied polymer modified binders	54
9.1.2 Polymer modified emulsions	55
9.1.3 Bitumen rubber	56
9.2 Contamination	57
9.3 Quality assurance	57
9.4 Site quality control plan	60
10. SAMPLING AND TESTING	61
10.1 Sampling	61
10.1.1 Safety precautions	61
10.1.2 Sampling containers	61
10.1.3 Monitoring of product during handling	61
10.1.4 Storage of samples	62
10.1.5 Sample preparation	62
10.2 Testing of modified binders	63
10.3 Asphalt mix design	63
11. PROTOCOL FOR INTRODUCING A NEW MODIFIED BINDER PRODUCT	64
11.1 Laboratory testing	64
11.2 Field trials	65
APPENDIX 1 – TEST STANDARDS	67

APPENDIX 1: SAMPLING AND TESTING

METHOD MB-1:	Sampling of modified binders	79
METHOD MB-2:	Sample preparation	81
METHOD MB-3:	Modified rolling thin film oven test	83
METHOD MB-4:	Elastic recovery of polymer modified binders by ductilometer	86
METHOD MB-6:	Storage stability of polymer modified binders	91
METHOD MB-8:	Pull out test method for surfacing aggregate	92
METHOD MB-10:	Ball penetration and resilience of bitumen-rubber blends	96
METHOD MB-11:	Compression recovery of bitumen rubber binders	99
METHOD MB-12:	Flow test for bitumen-rubber binders	101
METHOD MB-13:	Dynamic viscosity of bitumen-rubber binders	103
METHOD MB-14:	Particle size distribution and loose fibre content of rubber crumbs	105
METHOD MB -16	Bulk density of rubber crumbs	
METHOD MB-17:	Softening point of modified bitumen by ring and ball method	107
METHOD MB-18:	Dynamic (Apparent) viscosity of polymer modified binders	107
METHOD MB-20:	Recovery of residue of modified bitumen emulsion	108
METHOD MB-21:	Viscosity of modified bitumen emulsions	110
METHOD MB-22:	Water content of modified bitumen emulsions	110
METHOD MB-23:	Residue on sieving of a modified bitumen emulsions	111
METHOD MB-24:	Particle charge of modified bitumen emulsions	111

1. INTRODUCTION

Modified binders have the ability to offer improved performance over conventional binders, but do not offer a universal solution for all situations.

Benefits that may be derived from binder modification include:

- Improved consistency;
- Reduced temperature susceptibility;
- Improved stiffness and cohesion;
- Improved flexibility, resilience and toughness;
- Improved binder-aggregate adhesion;
- Improved resistance to in-service ageing.

However, irrespective of the improvement in binder characteristics, the fundamental rules of design of asphalt or surfacing seals (including aggregate quality, layer stiffness/flexibility and workability) should not be ignored.

Modified binders are generally more expensive than conventional binders; hence, their correct application does not lie in the simple substitution of conventional binders, but requires appropriate design of the final product in order to maximise the cost-effectiveness relevant to a specific situation. Very often performance requirements for routine situations can be met with the use of appropriate conventional binders. There are, however, particular situations where modified binders could offer cost-effective solutions.

Typical conditions where such binders should be considered are given below.

Surface Seals

- In areas of high stress such as heavy traffic, steep inclines, intersections (modified tack coat for Cape Seals) and sharp curves;
- In areas experiencing large daily/seasonal temperature fluctuations or high ambient temperatures for long periods;
- As a Stress Absorbing Membrane Interlayer (SAMI);
- For sealing over active cracks of up to 3 mm without pre-treatment (Stress Absorbing Membrane, SAM);
- In slurry seals for heavy duty applications (e.g. rut filling);
- In remote areas where improved durability is required.

Hot-Mix Asphalt

- On relatively highly flexible pavements;
- In areas of high stress such as heavy traffic, steep inclines, intersections and sharp curves;
- In asphalt bases which are subjected to high loading under slow moving traffic;
- In areas experiencing large daily/seasonal temperature fluctuations or high ambient temperatures for long periods;
- In areas that are subjected to fuel spillages;
- In open graded mixes requiring a high binder film thickness;
- In areas where thin layer overlays are required.

Bond Coat

An application of bituminous binder under asphalt layers to improve layer adhesion (thereby reducing the risk of delamination) and preventing pick-up by construction vehicles.

Crack Sealing

- For cracks wider than 3 mm;
- For highly active cracks.

Rejuvenators

With the current international trend towards more sustainable practice, recycling of non-renewable materials is becoming the norm. While these products modify bituminous product properties and could, in a sense, be categorised as "bitumen modifiers", they have not been included in this document. The majority of these products are currently "proprietary" in nature

and, as such, fall outside of the scope of this guideline at present.

Warm mix technology

As in the case of rejuvenators above, “warm-mix” additives can provide both environmental and engineering benefits in the use of bituminous products, particularly asphalt. However, as in the above, these products are still in a “propriety” stage at present and no generic specification is currently in place. Practitioners are advised to investigate and select the most appropriate product for their specific conditions and application. More information on warm mix asphalt (WMA) is provided in Section 7.

2. OCCUPATIONAL HEALTH, SAFETY AND THE ENVIRONMENT (HSE)

Personnel involved in the manufacture, storage, transport and application of modified bituminous binders must be aware of the health and safety hazards and effects attached thereto, as well as to the environmental aspects that have the potential to cause harm to people and the environment in which they work. Users should consult the Material Safety Data Sheets (MSDS) available from the supplier to determine and assess the hazards associated with the use of the binder in question, and to institute appropriate mitigating action.

The general HSE hazards and effects associated with bitumen and bituminous binders are well documented in various Sabita publications. In this section the most critical HSE hazards and effects specific to modified binders are highlighted and discussed in some detail.

2.1 Safety hazards

2.1.1 Elevated temperature

As for conventional binders the most common hazard and effect associated with the handling of modified binders is elevated temperature that could lead to severe burns when the hot liquid, or hot equipment, makes contact with unprotected skin of the human body. Hot modified binders are generally applied at higher temperatures than conventional binders to offset the increase in viscosity. The application temperature could be as high as 200°C.

2.1.2 Flammable vapour and ignition sources

Modified binders are normally handled at temperatures below the specified minimum flash point, and should not present a significant fire or explosion risk if handled correctly. At normal ambient temperatures bitumen is considered not combustible or flammable. However it should be noted that:

- Some of the modifiers used in the production of polymer modified binders, e.g. SBS and EVA, are flammable and must be handled with care in the manufacturing process;
- If heated to a high enough temperature, bitumen will vaporise and the vapour will flash in the presence of a spark or open flame;
- If petroleum cutters are used to reduce the viscosity of the binder the fire risk increases significantly. (See Sabita publication *Field production of cutback bitumen*, January 2013).

2.1.3 Reactive bitumen foaming ('boil over')

Hot bitumen reacts violently with water causing reactive bitumen foaming. Flammable vapours are evolved within the reaction process substantially increasing the risk of fire and explosion if an ignition source is present.

Reactive bitumen foaming may also result in 'boil over' in a tank or vehicle compartment leading to spillage of hot bitumen.

2.1.4 Controlling the safety hazards

The following precautions are required to minimise exposure to hazards:

- All modified bitumen handling plant and equipment that operates at elevated temperatures must have thermal shielding installed;
- Appropriate signage is required to indicate the presence of extremely hot surfaces;
- Appropriate Personal Protective Equipment must be worn to protect against contact with hot surfaces or liquid;
- Vapours should be controlled/dispersed by venting, particularly when the substances are used under conditions exceeding their flash point;
- Ignition sources in confined spaces, where flammable vapour mixtures may be present, must be eliminated. For example, sources of naked flames and practices such as open-flame heating of spray bars are not permitted;
- Self-heating of hot deposits within bitumen tanks and vessels should be eliminated by keeping hatches closed to exclude air low and by preventing (pyrophoric and carbonaceous) deposit build-up through regular inspection and maintenance of tanks and vessels
- Exclude water from bitumen to prevent reactive liquid bitumen foaming and 'boil over'. Ensure that pipes, valves, hoses and tanks are free from water or contaminants;

- Test and ensure that cutter oils, solvents and other bitumen additives are not contaminated with water;
- Ensure that water does not enter into tanks or vessels containing bitumen at elevated temperatures, particularly during firefighting or emergency tank cooling procedures.

2.2 Health hazards

2.2.1 Terminology – vapour and fumes

The terms “vapour” and “fumes” are invariably used as a generic description for emissions, but in fact there is a subtle difference in meaning when applied to occupational hygiene.

“Vapour” usually refers to the gaseous state of a liquid (usually a volatile liquid) that evolves when “vaporisation” takes place on the surface of a liquid. Vapour consists of very fine sub-microscopic droplets diffused or suspended in the air and vapour could be odourless or have very distinct odour. Vapour can sometimes be seen as a vapour cloud, but normally the vapour is “invisible” to the naked eye.

“Fumes” are formed when vapour from “volatilised” bitumen condenses in cool air. Fumes contain microscopic solid particles and are usually quite visible in the form of smoke or a “mist” suspended in the atmosphere.

Considering the above definitions and for purposes of this discussion, “bitumen fumes” can best be described as “vapour containing suspended solid particles that could be harmful to humans if inhaled”.

2.2.2 Potential health hazards and effects of modified bitumen

The presence of very low concentrations of Polycyclic Aromatic Hydrocarbons (PAHs) in bitumen has raised concerns regarding the potential for adverse health effects in workers exposed to bitumen or to bitumen fumes. Because some PAHs are carcinogenic, a possible cancer risk has been the primary concern.

However, numerous studies in the USA and Europe have been conducted on the health effects of occupational exposure to ‘conventional’ bitumen and ‘modified bitumen’ including polymer modified bitumen, and the overall consensus of these studies can be summarised as follows:

Acute health effects

Eye, nose, and throat irritations are the most common effects of exposure to bitumen fumes, including those emanating from modified bitumen.

Although no definitive results have yet been obtained, the trends are suggestive that exposure to polymer modified bitumen are potentially more hazardous.

Chronic health effects

Research into the longer term effects of exposure to bitumen fumes is ongoing, and is in particular focussed on the potential of the incidence of cancer in workers exposed to bitumen fumes. Results have thus far been inconclusive; however researchers remain cautious and currently classify bitumen fumes as ‘possibly carcinogenic to humans’.

2.2.3 Increased likelihood of exposure to harmful fumes during handling and application of modified bitumen

According to an EPA publication *Safe handling advice when working with polymer modified bitumen*, comparative studies of emissions from standard paving grades and SBS-modified bitumen confirmed that under correct working conditions there was no significant increase or differences in fume formation. However, studies also acknowledge that:

- Modified bitumens contain additives that are potentially more hazardous. For example, some extender oils contain high concentrations of harmful Polycyclic Aromatic Hydrocarbons (PAHs) and every precaution must be taken to reduce the exposure of workers to fumes. Manufacturers’ recommendations for each product should be followed;
- Modified bitumen is produced, stored and applied at higher temperatures compared to conventional binders and therefore, if strict temperature control is not exercised, the potential for emission of toxic fumes is increased.

2.2.4 Controlling the health hazards

Minimising personal exposure to fumes from modified bitumens is the only practical way to control the potential ill-health effects of bitumen fumes. The following control measures must be given due consideration in application methods and operating procedures:

- Health risk assessments must be conducted to identify specific tasks where workers are at risk of exposure;
- Personnel must be made aware of the potential harmful effects of bitumen fumes. A Material Safety Data Sheet

(MSDS) for the specific modified bitumen must be available to personnel involved in the handling and application of the binder;

- Personnel must be adequately trained, instructed and supervised to ensure compliance with safe operating procedures;
- Work should be carried out at the lowest operating temperature commensurate with best practices for handling and compaction;
- Exposure to fumes should be minimised by ensuring adequate ventilation and safe work practices at the work site (including simple practices, e.g. standing upwind of the source of fumes). Periodic exposure monitoring should also be carried out;
- Appropriate respiratory protection must be provided to any personnel working in areas where bituminous fume is likely to be in their breathing zone (See Figure 1 below);

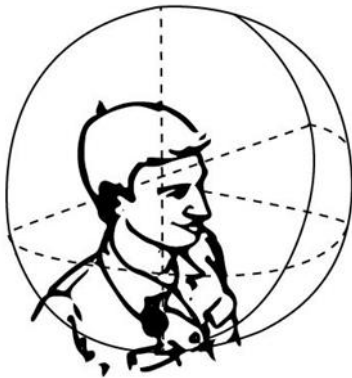

The breathing zone - a hemisphere of 300 mm radius extending in front of a person's face measured from the mid-point of an imaginary line joining the ears

Figure 1 Breathing zone

2.3 Environmental aspects

Generally, bitumen is considered to be a non-ecologically toxic product which presents no danger to plant and aquatic environments. Available literature on the potential impact of bituminous products does not make specific reference to polymer modified bitumen. It is therefore not clear whether the addition of modifiers will have an increased likelihood of adverse effects on the environment.

2.3.1 Prevention of spills

Notwithstanding the above it should always be remembered that large spillages of hot liquid bitumen, regardless of the binder composition, could have a devastatingly acute local effect, especially on plant life. Prevention of spillage should always be a top priority in the design and operation of blending facilities and transport and paving equipment.

2.3.2 Air emissions

The addition of modifiers may have a tendency to increase the concentration of pollutants in air emissions at production facilities. Emission controls required in terms of the Air Quality Act, 2004 should be properly maintained and carefully monitored to ensure that emission limits are not exceeded.

2.4 Literature

With this revision of TG1 the following publications were consulted to ensure current knowledge and information is included in the revision:

- Hazard Review: Health Effects of Occupational Exposures to Asphalt*, National Institute for Occupational Safety and Health, U.S. Department Of Health And Human Services;
- Crumb-Rubber Modified Asphalt Paving: Occupational Exposures and Acute Health Effects*, Niosh Health Hazard Evaluation Report: Heta #2001-0536-2864;
- Health, Safety & Environmental Aspects of Bituminous Materials*, Australian Asphalt Pavement Association, 2010;
- Occupational exposures to bitumen and their emissions*: WHO/International Agency for Research on Cancer, October 18, 2011;
- Life Cycle Inventory: Bitumen*, 2nd Edition July 2012, Published by the European Bitumen Association;

- vi. *The Asphalt Paving Industry - A Global Perspective: Production, Use, Properties, and Occupational Exposure Reduction Technologies and Trends*, Second Edition, Global Series 101, Produced February 2011.

3. COMPOSITION AND CHARACTERISTICS

Bituminous binders behave differently under different temperature and load conditions. At lower temperatures or short duration of loading, the binder tends to be stiff and elastic while at higher temperatures or prolonged loading, there is more flow or plastic behaviour. At intermediate cases of temperature and loading, the binder will act as a combination of the two behavioural conditions. Further details of the viscoelastic characteristics of bitumen can be found in Sabita Manual 2: *Bituminous binders for road construction and maintenance*.

Similar to conventional binders, the physical properties of modified binders are largely controlled by the fundamental properties related to temperature, viscosity and phase transition. Modified bitumen provides the technology to produce a bituminous binder with improved viscoelastic properties which remain in balance over a wider temperature range and loading conditions.

There are four distinct modes of interaction between bitumen and modifiers:

- The modifier is present as a separate phase within the bitumen;
- The bitumen is present as a separate phase in the modifier and the product will display the properties of the modifier rather than the bitumen;
- The modifier will form an interface with the bitumen, giving greater elasticity due to changes in the mechanical structure of the material;
- The modifier will form a molecular bond with the bitumen giving greater elasticity and stiffness to the material.

3.1 Composition of bitumen modifiers

Modified binders have been divided into the following two broad compositional groups:

- **Homogenous binders** which are defined as a blend of polymer and bitumen where two distinct phases cannot be detected on a microscopic level, or, where the two phases are interwoven to such an extent that the material behaves as a single-phase material from a confined, localised perspective. Examples of homogenous binders are EVA, RET, SBR and SBS polymer modified binders (see below);
- **Non-homogenous binders** are where there are two distinct, detectable phases and where there will be localised differences in properties depending at what stage a test is performed. Bitumen-rubber falls into this category as it consists of rubber crumbs partially dissolved in a bitumen matrix. The familiar conventional bitumen-rubber binder has recently been supplemented by an enhanced product that facilitates handling and application at lower temperatures, has extended shelf life and displays improved rheological properties. This category of bitumen-rubber is presented as a different class;

- **Hybrid modified binders¹**

Blends of different polymers types;

- Blends of polymers and rubber crumbs;
- Blends of polymers and WMA additives;
- Blends of rubber crumbs, WMA additives and/or polymers.

They can also be considered in two distinct application modes; those which are hot applied and those which are cold applied either by emulsifying and/or cutting back.

Cold applied products in the form of bitumen emulsion or cutback bitumen are also available for use in the road building industry. Only bitumen emulsions are normally modified to improve the residual bitumen's viscoelastic properties. Cutters are sometimes added to hot binders to reduce their viscosity and improve their ability to wet the stone aggregates during surfacing seal applications in cooler weather conditions.

The homogeneous polymer modifiers typically used in bitumen modification are thermoplastic polymers such as:

- Styrene-butadiene-styrene (SBS) block copolymers (Elastomeric);
- Blend of S, WMA additive and cross-linking agent (Elastomeric);
- Synthetic styrene-butadiene-rubber (SBR) latex (Elastomeric);
- Styrene isoprene rubber (SIR) (Elastomeric);

¹ Blends with rejuvenators are excluded

- Natural rubber latex (Elastomeric);
- Ethylene-vinyl-acetate (EVA) block copolymers (Plastomeric);
- RET (Reactive Elastomeric Terpolymer).

The non-homogenous bitumen-rubber utilises crumbed rubber from recycled tyres.

For cold applied products, the rheological properties of bitumen in the emulsion can either be modified by the pre-modification of bitumen, or by the post-modification of the bitumen emulsion. In South Africa, the post-modification of the bitumen emulsion is the most popular practice. Natural rubber or synthetic rubber latex such as SBR or SIR can be used to improve the properties of bitumen in the various applications.

Each of the different types of modified bitumens will be discussed separately in order to describe the benefits and sensitivity to application of each of the various modifiers.

Note: The modification of emulsions for fog-spray applications is not recommended!

The latex emulsion breaks first, forms a skin and prevents the bitumen emulsion from breaking. This causes the rubber to lie on top of the road surface, where it is picked up by traffic.

3.1.1 Homogeneous binders

Styrene-Butadiene-Styrene (SBS)

SBS is a block copolymer and can be classified as either linear or radial. A radial blocked copolymer results in much higher viscosity and softening point for the same addition of polymer making it more difficult to mix with bitumen, compared with the linear block copolymers.

SBS can be considered as a thermoplastic rubber and is characterised by its glass transition point (Tg). Coherent cross-linking points provide high stiffness below the glass transition point. The process is reversed by melting (100°C) the copolymer

Styrene and butadiene are mutually incompatible and attempt to separate in the modified binder mix. However, as the copolymers are chemically linked, styrene end blocks agglomerate and form three dimensional cross-linked polystyrene domains which give the polymer mechanical properties comparable to cross-linked rubber (vulcanisation). Since the cross-linking is physical rather than chemical, the process is reversible.

At elevated temperatures above the glass transition point of the polystyrene domains, the physical cross-links dissociate. On cooling, the domains reform and the physical cross-links with long continuous elastic networks reform and are restored within the bitumen.

SBS absorbs the maltenes in the bitumen, swells and, at higher dosage levels, forms a continuous molecular network in the bitumen phase which makes up a major fraction of the bitumen by volume. At lower concentrations (3 - 4%) the SBS will only form a fragmented molecular network. At higher concentrations (4 - 6%) a continuous network forms which results in a dramatic increase in the softening point. The molecular networks increase the elastic component of bitumen which assists with recovery after deformation. As the SBS content is increased, the elastic recovery also increases.

The effect that an increase in the amount of SBS polymer will have on the softening point of base bitumen with varying asphaltene contents is shown in Figure 2. The rate of increase in the softening point and thus the shape of the curve is dependent mainly on the asphaltene content of the base bitumen, the type and grade of the SBS polymer and the percentage thereof. Typically, the curve assumes an S-shape as the SBS structure changes from a fragmented form to a continuous network in the modified binder.

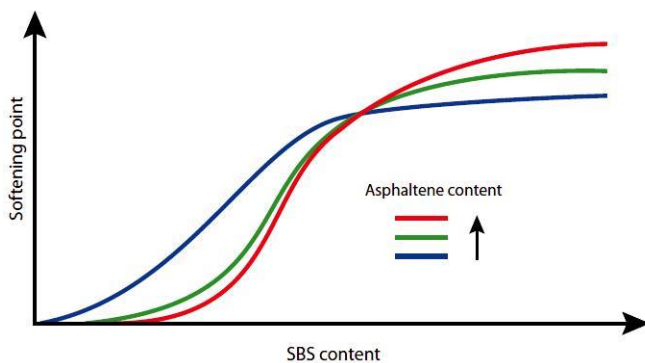

Figure 2: Typical effect of SBS on the softening point of bitumen with different asphaltene contents

An apparent correlation exists between elastic recovery and deformation resistance in that an increase in elastic recovery provides for better deformation performance. Cohesive strength also increases with the increased elastic recovery. SBS hot

modified binders are generally preferred to SBR due to their higher softening points and higher elastic recovery properties, which in turn can be applied at lower temperatures as a result of their lower relative viscosities.

At low temperatures, the addition of SBS improves the flexibility of the bitumen which inhibits cracking and improves the resistance of the binder to crack reflection.

Blend of SBS, WMA additive and cross-linking agent

This concept in modification involves co-modification with an SBS and a WMA additive, thereby enhancing the elastic recovery, providing the benefits of reduced mixing and placing temperature and the high temperature deformation resistance behaviour imparted jointly by the individual components. It utilises a cross-linking technology to improve polymer-bitumen compatibility, and enables the production of polymer modified bitumen with controlled consistency. The final product exhibits a continuous polymer phase with excellent storage stability.

The benefits of this technology include:

- The improved dispersion capability dispenses with the requirement of a high shear mixer, enables lower dispersion temperature and, hence, reduces energy consumption;
- The cross-linking agent reduces the effect of thermal degradation of SBS that can usually be observed in non-cross-linked bitumen-SBS blends;
- A stable modified bitumen, free of inconveniences normally associated with phase separation;
- Reduced viscosity, permitting more efficient blending, aggregate coating, aggregate adhesion, storage, transportation, laying and compaction;
- The compaction resistance of asphalt mixes is reduced yielding an extended paving and compaction window, particularly in cold climates and under adverse weather conditions;
- The lower viscosity enables lower spray temperatures in surfacing seal applications.

Styrene-Butadiene-Rubber (SBR)

SBR latex consists of styrene butadiene polymer, emulsified with a solids content generally greater than 50% depending on the grade. The SBR latex is manufactured through the copolymerisation of the hard styrene monomer and the soft butadiene monomer. The butadiene contributes to the elasticity and makes the binder more flexible whereas the styrene gives stiffness and strength to the material.

The mechanical bonding mechanisms and chemistry of SBRs are very similar to those of SBS, with the exception that during the copolymerisation of the butadiene, single-unit monomers are randomly linked to form long, multiple units.

SBR latex is used in both hot and cold modified binders. However, the emulsifier type becomes very important when selecting the SBR-latex for the modification of bitumen emulsions. Anionic latex emulsifiers are used with anionic emulsion and, similarly, cationic latex emulsions are used with cationic bitumen emulsion grade.

SBR modified binders are predominantly used in cold applied binders for seals, bond coats, crack sealants and microsurfacing. Hot modification of bitumen with SBR is still commonly used for seals and, to a lesser extent, in asphalt. With the modification of hot bitumen the amount of SBR latex that can be added is limited by:

- the rapid increase in the binders viscosity which is in turn restricted by the spray temperature; and
- the evaporation of the water content of the latex when blending with the hot bitumen
- SBR polymers improve adhesion of the binder with the aggregate in sealing applications, which results in better chip retention. They also provide improved elasticity and flexibility to the binder, seal cracks and prevent water ingress into the pavement. In asphalt applications they increase the deformation resistance, enhance fatigue properties and retard crack reflection.

Natural rubber latex

Natural rubber latex consists of polymerised isoprene monomers which increase the elasticity of the bitumen. However, the natural rubber latex is more sensitive to heat and is therefore mainly used in the modification of cold bituminous binders. The addition of latex to emulsion also provides a cold product which can be used for sealing fine cracks of width less than 3 mm.

EVA (Ethylene-Vinyl-Acetate)

EVA is a polymeric plastomer which consists of two monomers ethylene and vinyl-acetate (VA). The two monomers form long crystalline molecular strings which dissociate when the temperature is increased above the material's glass transition point.

The morphology of EVA is semi-crystalline and interconnected by polyethylene crystalline molecules and vinyl-acetate molecules which form amorphous chains contributing to the flexibility.

The polyethylene provides the stiffness to the material with cohesion provided by the crystallinity and chain length. The

copolymers are polar and, together with the maltenes of the bitumen, will dictate the compatibility and adhesive properties of the binder. The following main parameters control the properties of EVA:

- Vinyl Acetate (VA) content: The more the VA content increases, the higher the proportion of rubbery regions (i.e. an increase in flexibility) and the lower the proportion of crystalline regions (i.e. a decrease in stiffness).
- Molecular weight: Standard practice for EVA's is to measure melt flow index (MFI); the higher the MFI the lower the molecular weight and viscosity.

EVA modified bitumens have the ability to provide improved resistance to rutting in hot-mix asphalt compared to conventional bitumen along with improved compatibility, safer handling and better workability compared to SBS and SBR modifiers. Some grades of EVA also increase the resistance to damage caused by fuel spillages and pose no problems with future recycling of the material. However, it should be noted that the properties of EVA vary for different grades depending on the chain length and molecular weight of the polymer, the vinyl acetate (VA) monomer content and the crystallinity. In terms of the EVA modifiers, the VA content and melt flow rate (MFR) are as important as the styrene content and linear or radial structure in SBSs when determining specific properties.

EVA modified bitumen is also more heat stable and does not deteriorate as fast as SBR and SBS modified bitumen products at elevated temperatures during storage. Storage stability will therefore be better than that of SBS and SBR.

The compatibility of bitumen and EVA may vary, depending on the composition of the bitumen and the type or grade of the modifier.

RET (Reactive Elastomeric Terpolymer)

Reactive Elastomeric Terpolymer chemically reacts with bitumen. Asphalt mixes made with bitumen modified with RET have the ability to provide improved rutting resistance and improved resistance to the adverse effects of fuel spillages. RET consist of three polymers (and also goes under the name of ENBAGMA).

- **Ethylene**
 - being a hydrocarbon it is compatible with bitumen;
 - provides stiffness and viscous properties to prevent rutting.
- **n-Butyl Acrylate**
 - provides elastomeric properties to prevent cracking and rutting;
 - improves adhesion to aggregates.
- **Glycidyl Methacrylate**
 - reacts with bitumen to provide a homogeneous, storage stable modified binder.

3.1.2 Non-homogeneous binders

Bitumen-rubber

Bitumen-rubber comprises a hot bitumen, modified by the addition of conventional ground tyre rubber or alternative rubber compounds (with a specific, grading, morphology and composition) to produce a non-homogeneous binder. In addition, a more recently available product range may contain varying levels and / or types of additives and modifiers to enhance the ease of handling through lower handling and application temperatures and to extend storage life.

Rubber is obtained by processing and recycling rubber tyres, and it is important to note that the type of tyre rubber varies depending on the sources and make of the tyre. The natural rubber and synthetic rubber content will also vary depending on the source. The morphology of the rubber particles significantly influences the composition of crumbed rubber after mechanical grinding. Table 1 shows typical requirements for rubber crumbs for modified bitumen.

Table 1: Requirements for rubber crumbs for modifying bitumen

Property	Requirement	Test Method
Sieve analysis (% mass)		
Passing screen		
1,0	100	MB-14
0,600	40 - 70	
0,075	0 - 5	
Fibre length (mm)	6 max	
Bulk density (kg/m ³)	300 - 400	MB-16

The rubber crumbs and bitumen are blended at a temperature in excess of 180°C and involves the absorption of some of the maltene fraction of bitumen into the rubber. The rubber particles swell with some becoming totally digested by the bitumen, but most are only partially digested and increases the viscosity of the bitumen dramatically.

Note: The values reflected in Table 1 are typical, and cannot be used for specifying the components of a bitumen rubber blend. The onus rests on the supplier to meet the required specifications.

Digestion of the rubber is a continuous process and occurs at a higher rate at higher temperatures. Should the rubber crumbs become totally digested by the bitumen, the desired properties that the rubber crumbs give to the bitumen will be lost. Hence, special care is required during the manufacture and application of bitumen rubber. The product will have a shelf-life that varies depending on the manufacturer’s technology, time and temperature at which the product is stored.

When the bitumen rubber blend cools down the coarse rubber particles form a rubber network which is filled with bitumen and it is the rubber network that contributes to the improved cohesion, elasticity, flexibility, re-healing capabilities and strength of the material. Bitumen rubber has been used successfully in both surfacing seal and asphalt applications due to its improved elasticity and stiffness and can be used as a stress absorbing membrane interlayer (SAMI). The stone retention properties, resistance to bleeding and resistance to deformation are also enhanced.

The typical composition of bitumen rubber is shown in Table 2. However, the ratio of components varies depending on the bitumen source, the climatic conditions and the application. With the addition of extender oil the maltenes in bitumen remains virtually unaffected and improves the fatigue and durability characteristics of the binder. The requirements of the extender oil are such that it should have a flash point of greater than 180°C and a percentage by mass of aromatic unsaturated hydrocarbons greater than 55.

Table 2: Typical composition of bitumen rubber

Component	Percentage by mass
Bitumen	72 - 82
Extender oil	0 - 4
Rubber crumb or composite rubber compound ¹	18 - 24
High boiling point fluxing agent	0 - 4
Additives	0 - 4

¹ The user should liaise with the supplier of the compound or the A-R2 binder regarding the actual percentage of rubber crumb in the compound in relation to the asphalt filler content.

Note:

Extender oils and high boiling point fluxing agents are different in nature and have different properties and purposes

Rubber crumbs also contain other components that may have a beneficial effect on the properties of the binder. For example, the crumbs contain in excess of 30% carbon black which has been shown to add reinforcing properties to bitumen and antioxidants in the rubber contribute to the durability of bitumen rubber.

3.1.3 Naturally occurring hydrocarbon modifiers

Naturally occurring hydrocarbon products from the Americas are mainly used to reduce the temperature susceptibility of asphalt mixes by raising the softening point, stiffening or hardening the bitumen giving increased viscosity and reduced penetration values.

North American Asphaltum is a natural, resinous hydrocarbon found in Utah, USA, soluble in aromatic and aliphatic solvents and is frequently used to harden petroleum products. The black, shiny, free-flowing, granular substance is brittle and easily crushed into a dark brown powder that is fully compatible with bitumen. It has a high asphaltene (71%) and nitrogen (3%) content and is essentially sulphur-free (0.3%). It is 99% pure in its natural state, is low in toxicity and is non-carcinogenic.

South American Asphaltum originates from Argentina and is a natural bitumen of high purity, composed of hydrocarbons, asphaltenes and aromatics of high molecular weight. Table 3 shows a comparison of the composition of Asphaltum and a typical bitumen.

Table 3: Comparison of the composition of naturally occurring hydrocarbons (%)

Component	Asphaltum Ex North America	Asphaltum Ex South America	Typical Bitumen
Asphaltenes	71	>80%	8 - 18
Resins & Aromatics	27	High molecular weight aromatics	70 - 90
Saturates	2	-	4 - 10

Asphaltum can provide increased mix stability, helps to reduce rutting and shoving because it increases the load bearing capability, reduces temperature susceptibility of asphalt and imparts improved aggregate adhesion and resistance to water stripping. It is fully compatible with bitumen allowing for good stability in storage.

3.1.4 High molecular weight waxes

These long carbon chain alkanes, or n-alkanes, are synthesised using the Fischer-Tropsch (F-T) process of converting reformed natural gas into hydrocarbons. The chain lengths of these waxes are between 40 and 120 carbon atoms compared to crude oil wax with typical carbon numbers between 20 and 50 carbon atoms.

The F-T waxes act as “flow improvers” and have the ability to reduce the viscosity of the modified bitumen during mixing and compaction of hot-mix asphalt, thereby allowing lower temperatures during these processes, as is the case with warm-mix asphalt.

F-T waxes increase the softening point and decrease the penetration value of the binder. As a result handling of the modified binder at elevated temperatures is facilitated, while at service temperatures the deformation resistance of asphalt is enhanced. Figure 3 shows the effect of F-T wax modification of a binder on its viscosity over the in-service and application temperatures zones as compared to conventional bitumen.

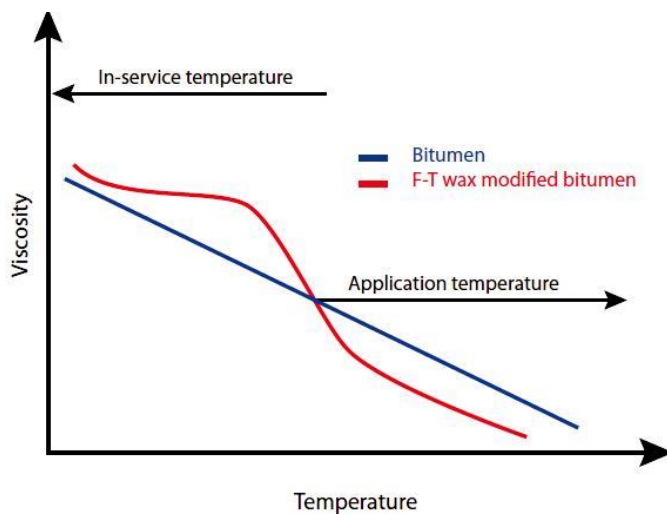

Figure 3: Typical effect of F-T wax on viscosity over temperature

The F-T wax modified bitumen has good aggregate adhesion, provides satisfactory stiffness at the higher operating temperatures and resistance to cracking at low operating temperatures.

The F-T waxes are completely compatible with bitumen and are stable in storage. They can also be used as a co-modifier with polymer modified bitumen to produce hybrid products that may be tailored for specific engineering requirements for improved long-term performance of asphalt layers. It is recommended that the manufacturer’s guidelines on blending and construction practice be followed to derive maximum benefit from the use of this modifier.

3.1.5 Polymer modified bitumen emulsions

There are two methods of producing polymer modified emulsions:

1. In the first method, rubber latex, which is a stable dispersion (emulsion) of rubber particles in water, is incorporated in the aqueous phase before co-emulsification with the bitumen in the colloid mill. The manufacturing conditions are similar to the conditions employed for producing conventional bitumen emulsions. This type of emulsion is called a three phase emulsion, as it consists of bitumen and rubber droplets dispersed in the water phase. Typically, Styrene Butadiene Rubber (SBR) latex would be used for the modification of bitumen emulsions.

- The second method involves pre-dissolving the solid polymer – typically SBS – in the bitumen before emulsification. The final emulsion thus consists of two phases i.e. polymer modified bitumen droplets dispersed in the aqueous phase. As the polymer modified binder has a considerably higher viscosity than conventional penetration grade bitumen, it is necessary to heat the modified binder to an elevated temperature to ensure proper emulsification in the colloid mill. Due to the higher temperatures employed, the emulsion exit temperature from the colloid mill will exceed the boiling point of water. To prevent the polymer modified emulsion from boiling upon exiting the colloid mill, it is necessary to cool the emulsion to below its boiling point, by passing it through a heat exchanger. SBS modified emulsions are currently not commonly available in South Africa.

SBR modified spray grade bitumen emulsions are characteristically slower breaking than conventional rapid-set bitumen emulsions, after application. Consequently, during surfacing seal operations with latex modified emulsions, sufficient time should be allowed for the water component to evaporate, before allowing traffic on to the surface.

3.2 Behavioural characteristics

The main purpose of bituminous binder is to:

- Act as an organic glue and waterproofing agent when combined with processed naturally occurring inorganic stone and sand;
- Provide appropriate performance characteristics to the materials in service that will improve their ability to withstand the environmental conditions to which they may be exposed. The most important characteristics that will be considered are:
 - Rheology;
 - Elasticity;
 - Cohesion;
 - Adhesion; and
 - Ageing and durability

3.2.1 Rheology (flow behaviour)

Rheology is the study of the flow and deformation behaviour of materials. Bituminous binders behave as visco-elastic materials, with their behaviour influenced by the loading time as well as the temperature. At high temperatures or long loading times, binders behave more like viscous liquids, and consequently can undergo large permanent deformation. At low temperatures or short loading times, binders behave like elastic solids, with most of the deformation recovered at the end of the loading cycle, but more prone to cracking.

The rheology of modified binders is complex, and, although the results from conventional tests may indicate a significant alteration in properties, the in-service performance of these binders is not easily categorised. The typical influence of type, as well as amount of modifier on viscosity and softening point properties is shown in Figures 4 and 5, respectively.

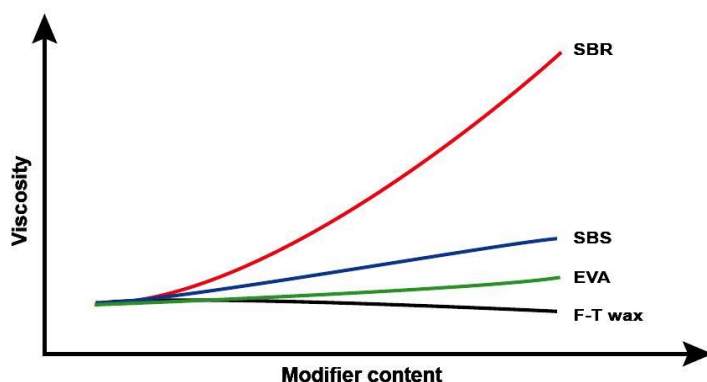

Figure 4: The typical effect of various modifiers on bitumen viscosity

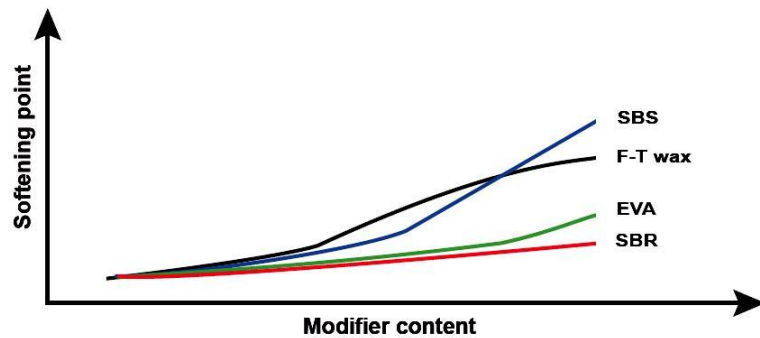

Figure 5: The typical effect of various modifiers on bitumen softening point

Selection of polymer type and grade, as well as the amount, will be dictated largely by the need to satisfy the minimum softening point requirement as well as achieving the specified application viscosity within the recommended maximum temperature limits, to prevent degradation of the product. This certainly is the case with SBR modified binders, as can be seen in in Figures 4 and 5, and users must be cautioned that by increasing the amount of polymer to meet the minimum softening point requirement will lead to a dramatic increase in the viscosity rendering the final product difficult to apply.

Experience has shown that there is a general tendency for the softening point values of polymer modified binders to decrease in storage over time. Where long haul distances or lengthy delays are expected, it may be necessary to slightly increase the percentage of modifier added. When assessing the acceptability of this product property (as with any other properties) cognisance should always be taken of the inherent uncertainty applicable to the test method.

Unlike conventional bitumen which displays Newtonian behaviour above its softening point temperature, modified binders tend to display shear thinning behaviour thus rendering dynamic viscosity measurements at normal shear rates of limited usefulness, particularly below application temperatures.

Thus the use of the standard procedure of the Brookfield viscosity test at one shear rate to determine asphalt mixing and compaction temperatures for modified binders is not appropriate. Using the viscosity limits commonly used for conventional binders, based on a single shear rate, lead to excessively high temperatures when compared to field experience and producers' recommendations. There is a prospect for using the Dynamic Shear Rheometer for estimating appropriate mixing and compaction temperatures for modified binders.

In most instances, the addition of a polymer results in the binder having lower moduli at low temperatures, and is therefore more flexible. At high temperatures, however, the binder exhibits an improved stiffness and elasticity when compared to the unmodified bitumen. The most common way of measuring rheological properties is through the use of the Dynamic Shear Rheometer (DSR), which applies a range of shear stresses at various frequencies (loading time) and temperatures.

3.2.2 Elasticity

Elastic behaviour indicates that the binder recovers most or all of its initial shape when the load that caused the deformation is removed. The elastic recovery of a binder is commonly used to measure the fatigue resistance of a binder or its ability to absorb large stresses without necessarily cracking or deforming.

Particular modifiers have unique elastic recovery characteristics depending on the morphology of the modifier/binder system. For example, SBS forms a three-dimensional network of highly elastic, butadiene chains connecting stiff styrene domains, resulting in very high elastic recoveries. SBR has random styrene/butadiene molecules, resulting in relatively lower elastic recovery. EVA forms a rigid three-dimensional network, imparting no elastic recovery properties to the base binder but provides a high stiffness.

The elastic property of a binder is generally influenced by the type of modifier as well as the degree of modification, and is determined by measuring the recovery of a sample which has been extended in a low temperature ductilometer. In cases where modifiers enhance elasticity, there is a direct relationship between elastic recovery and the degree of modification.

3.2.3 Cohesion

Cohesion is a measure of the tensile stress required to break the bond between molecules of the bituminous binder. The inherent strength, tenacity and toughness of the bituminous binders are improved by modification with thermoplastic polymers and rubber crumbs. Hence, a greater tensile stress is required to break the molecular bonds of modified binders and cause failure compared with a lower tensile stress required to break the bonds of conventional binders.

Although no longer a requirement in this document, the results of a force-ductility test illustrate the nature of the cohesive strength of modified binders. The test involves the elongation of a sample with the force measured at very small elongation

intervals. Figure 5 shows the typical profiles of various modified binder types obtained during the test.

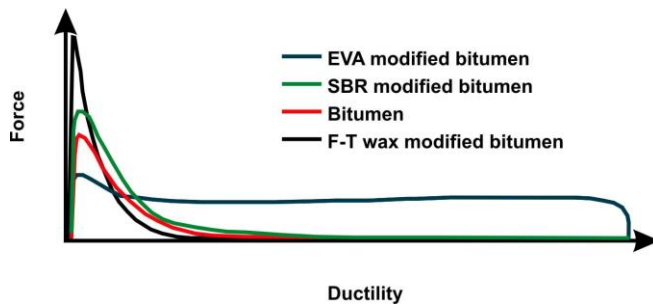

Figure 6: Typical force-ductility curves for various modified binders

As shown in Figure 6, the maximum force is reached early in the elongation process. The elastic phase is represented by the area before the initial peak and the total area under the curve can be used to calculate the energy required to extend the binder, which is a good indication of the binder's toughness or resistance to cracking.

The energy required to elongate elastomeric modified binders is generally significantly more than that for conventional binder. Plastomeric modified binders will impart stiffness to the bituminous binders but not necessarily improve its cohesive nature. Such modified binders may well perform in a brittle manner in tension.

The cohesive properties of modified binders provide guidance to how soon after construction a seal could be opened to traffic, as well as providing an assessment of the ability of the binder to withstand shear stresses imparted by heavy traffic.

3.2.4 Adhesion

Adhesion is a measure of the strength of the bond between the bituminous binder and mineral aggregate.

It is largely dependent on the physical and chemical nature of the bituminous binder and aggregate type when combined for application.

The following factors have an impact on adhesion at the stone/bitumen interface:

- Aggregate properties such as mineralogy, surface texture, porosity and absorption;
- The presence of dust and/or moisture which could reduce adhesion at the bitumen/aggregate interface;
- The binder concentration, hence film thickness, and filler type;
- The level of modification that influences the viscosity of bitumen which in turn affects the wetting ability or time to coat the road stone with bituminous binder. Wetting is an instantaneous process but if the viscosity of the modified binder is too high during application, wetting takes longer and poor adhesion can be expected;
- Ambient road and air temperatures and, especially, overnight temperatures;
- Temperature related adhesion failures of surfacing seals are typically associated with two factors:
 - For homogenous modified binders, the higher the level of modification, the higher the risk of adhesion failure due to decreased wetting ability and increased stiffness.
 - At colder temperatures, the higher stiffness of the binder results in a decrease in adhesion.

By increasing the film thickness of the binder layer the adhesion is improved. The film thickness of the binder layer can be increased by:

- Reducing the time-lag between the binder application and the stone application in surfacing seals;
- Using pre-coated stone;
- Using emulsion cover (fog) sprays to increase or correct the final binder application rate;
- Pre-blending an adhesive agent with the modified binder prior to spraying.

Temporary reduction of the viscosity by the addition of cutters during colder weather conditions also improves the adhesion

It should also be noted that different types of aggregates exhibit different adhesion behaviour depending on the chemical nature of the parent rock in terms of its hydrophilic (water-attractive) or oleophobic (oil-repelling) nature. Depending on the chemistry of the parent rock, the nature of the aggregate could vary. However, bitumen is oleophilic (oil-attracting) or hydrophobic (water-repelling). Therefore, based on the inherent character of the aggregate, it may or

may not react (form chemical, charge-related bonds) with water, but the presence of water will have a negative influence on the adhesion

Acidic aggregates are more hydrophilic than basic aggregates. Acidic aggregates will therefore have poor adhesion properties in the presence of water. Cationic spray grade emulsion overcomes this tendency when the free electrons on the aggregate form physical/electrical bonds with the positively charged bitumen and SBR latex droplets as shown in Figure 7.

Similarly and, especially in high risk applications and under difficult construction conditions, surface active chemicals in commercially approved adhesion promoters and pre-coating fluids have been used effectively to improve the adhesion properties. However, if these substances are used in conjunction with bitumen emulsions in the construction of a surfacing seal, they are known to retard the breaking characteristics of the emulsion.

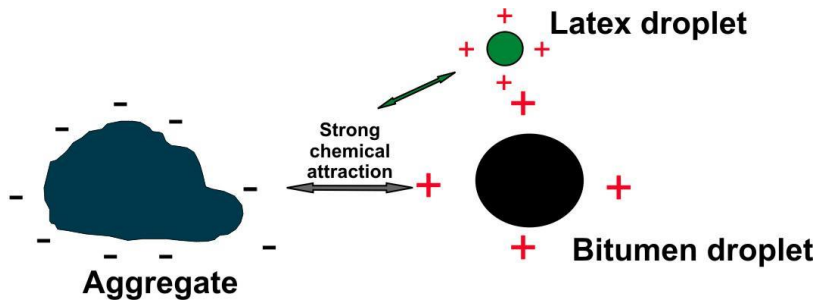

Figure 7 Adhesion characteristics of latex modified emulsions

3.2.5 Ageing and durability

The change in properties of bituminous binders over time is termed “ageing”, and is normally expressed as the difference between the original properties and the residual properties exhibited over time. Typical factors affecting the ageing of bituminous binders are the temperature and time-related conditions which results in a change in the viscoelastic behaviour.

In-service ageing describes the hardening (increase in stiffness and reduction of elastic properties) of a binder during its life on the road due to oxidation, loss of volatiles, physical hardening and exudation.

Degeneration and adverse changes in the properties of modified binders are also observed when bituminous products are stored at high temperatures. Durability of bituminous binders therefore relates to the ability of a particular binder in a specific application to resist the negative influence of ageing.

Temperature susceptibility

All bitumens display thermoplastic properties, i.e. they become softer (more liquid) when heated and harden when cooled. The degree of variation in consistency (or viscosity) is referred to as temperature susceptibility.

Conventionally it is characterised by Softening Point at elevated temperatures and Fraass Brittle Point at lower temperatures. This is characterised by the variation in consistency (stability) of the bitumen related to temperature and is governed by the softening point at high temperatures and, typically, the Fraass Brittle Point at lower temperatures. The window between the two extremes is called the service temperature of the bitumen with the two extremes being dependent on the crude source and bitumen grade. Should the binder be exposed to temperatures above the softening point bleeding/rutting could occur and below the brittle point, cracking may be observed (see Figure 8).

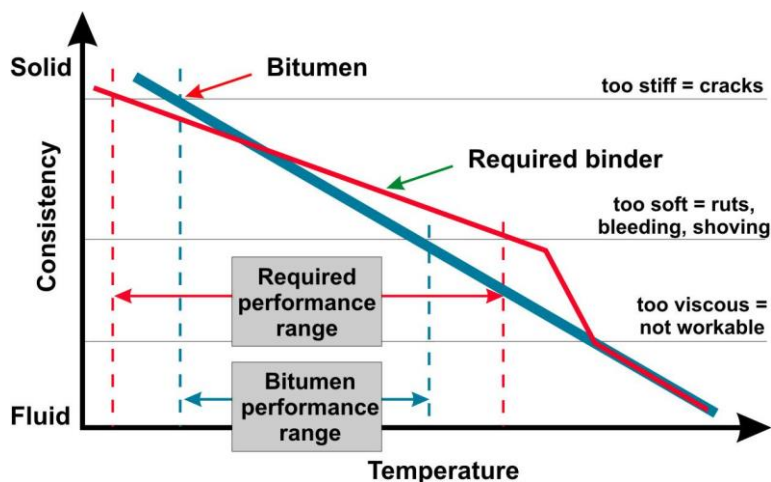

Figure 8: Schematic of viscosity of a binder over its working temperature range

By adding polymers to bitumen the in-service temperature range is widened. The increased stiffness compared to conventional bitumen enhances the performance characteristics of the modified bitumen and provides better protection against increased traffic loads and adverse climate conditions. In addition, thinner asphalt layers could be considered during design and construction/rehabilitation to reduce the cost of the pavement.

Certain modified binders, e.g. bitumen rubber, SBS and SBR materials are generally susceptible to thermal degradation. SBS and SBR are also susceptible to oxidation, making it important to monitor temperatures carefully during all stages – production, storage, mixing and application – of these modified materials.

Compatibility and stability

Compatibility of a polymer can be defined as its ability to remain distributed in the bitumen without phase separation occurring. This property is therefore an important attribute during handling and storage of the binder. However, the degree of compatibility varies by bitumen and by type and grade of polymer used in the formulation of the polymer modified product. Compatibility also varies with concentration of the polymer and the higher the concentration of the polymer, the lower the degree of compatibility. Total incompatibility could cause segregation and even gelling.

In a modified bitumen there is competition between the modifying agent (rubber crumbs, SBS, SBR or RET) and the naturally occurring asphaltenes for the available maltene portion (resins and aromatics) of the bitumen. This competition varies with the type and source of both the bitumen and the polymer, and this will affect the compatibility of the final product. Therefore any changes in the crude type and refining process used during the manufacture of the base bitumen could affect the compatibility of the polymer bitumen system.

The stability or homogeneity test as described in MB-6 is used to determine the compatibility of the base bitumen and the polymer in question and to assess the hot storage stability of a material.

As the application of mechanical stirring will inhibit segregation of the different components during storage, the stability test should be used by manufacturers as an indicator of whether stirring of their product is required or not. Also, whenever there is any reason to believe that the chemistry of the base bitumen has changed, the test should be repeated.

3.3 Use of cutters

As discussed in the previous sections, modification of bitumen with polymers or rubber crumbs tends to increase the cohesion of binders, and to render them more viscous at the expense of reducing the binder's ability to 'wet' the aggregate, resulting in the possible reduction of adhesion between the binder and stone. The reduction in adhesion could become critical when constructing a surfacing seal during cooler weather conditions. It is not uncommon for some modified binder seals to perform adequately in warm and dry conditions but to lose a considerable portion of aggregate during the first cold wet weather if inadequate work practices are not complied with.

Polymer modified binders are normally produced with 70/100 penetration grade bitumen. During lower temperature conditions it is necessary to soften the binder by utilising an appropriate hydrocarbon cutter, such as illuminating kerosene, to prevent stone loss by improving the adhesion properties of the binder and promoting the early formation of a stable mosaic of aggregate.

From a safety perspective, the practice of cutting back hot binders is a hazardous operation as the blending temperature of the binder is well in excess of the cutter's flash point. Ideally, this operation should only be undertaken under controlled conditions such as in a blending plant.

However, if the blending of the cutter has to be undertaken on site, the binder supplier must produce a written method statement of his blending procedures for cutting back modified bitumen. The reader is referred to the Sabita publication:

Guide for the control of HSE hazards associated with the field production of medium curing cutback bitumen.

It should also be noted that there is always the real risk that the use of a cutter can lead to bleeding of the newly constructed seal with the onset of warmer weather conditions under heavy traffic. Thus special care must be taken of all the factors that could affect the performance of the new seal if the modified binder is cut back.

3.3.1 Factors affecting the cutting back of modified binders

The following factors will influence whether it is necessary to cut back binder, and provides guidance on the appropriate quantity of cutter to use.

Road surface temperature

The road surface temperature at the time of spraying and the projected temperature for the next 24 hours is a critical factor with respect to risk of early stone loss. If the traffic spectrum dictates that the use of cutters would be inappropriate, then no spraying of hot modified binders should be done if:

- The expected maximum road temperature does not exceed 30°C for several hours during the application period. Sealing should only commence when the road surface temperature reaches 25°C and continues to rise above 30°C; or

- The expected minimum air temperature in the following 48 hours is expected to drop below 10°C. To this end the weather forecast for the ensuing week should be obtained to ensure that the minimum temperatures are not expected to fall below this value.

Shady areas

Where the road will be in shade during the day it is likely that the maximum road temperature in the shaded area would be below 25°C. In such locations cutting back should be considered, provided that such areas are large enough. However, these areas are often isolated in comparison to the overall project e.g. areas under bridge decks and thus the following options are recommended in place of cutting back:

- Increase the binder application rate by up to 20% for large areas. Alternatively, split the binder application by reducing the application rate of the tack spray and spraying a diluted emulsion as a cover spray;
- Start the application in the shaded areas and ensure that the distance between the sprayer and chip spreader is kept to a minimum;
- Where a significant length of the project is expected to be in shade, consider using an emulsion for the project and covering the seal with no-fines grit after the emulsion has broken. In addition, keep the shaded areas of the road closed to traffic for 48 hours. Care must be taken when using modified emulsions in cooler locations, because the latex in the emulsion forms a skin which inhibits the breaking process.

Time of the year

Cutting back of binders should not take place later than the beginning of September because it can take up to 3 months for the volatile fractions of the cutters to evaporate from the layer. The amount of cutter used should also be tapered off with the onset of warmer weather as spring approaches.

As some areas in South Africa experience night temperatures below 10°C in March, it is recommended that the minimum temperatures from the closest weather station for the preceding 10 year period be obtained prior to making any decisions as to whether to cutback or not.

Type of surfacing

The type of surfacing will also influence whether or not a cutter can be used. Cutters should not be used in the spray applications for:

- Cape seals, tack sprays for double seals, geofabric seals and SAMIs as they will be covered by a slurry, binder or asphalt which would lead to the entrapment of the volatiles.
- Seals to be placed over fresh asphalt or slurry surfaces (excluding texture slurries of less than 2 mm) as it could lead to premature embedment of the new seal. A ball penetration test should be done to determine the hardness of a new asphalt or slurry surface before resealing with a cutback modified binder.

Spray grades of modified emulsions usually contain 2 - 4% m/m of cutter (flux), which is varied seasonally to enhance the breaking and adhesion characteristics. The presence of cutter in the emulsion may cause bleeding in Cape seals carrying very heavy traffic, as well as instability in geofabric seals during warmer weather.

Expected traffic volume

The expected traffic volume, especially the number, type and load of heavy vehicles and the speed at which they travel on the seal, is a critical factor in determining whether to cut back or not. Modified binders that have been cut back tend to bleed where there is a high volume of heavy vehicles travelling at speeds below 40 km/h.

As a general guide, the use of cutters should be restricted to roads carrying less than 5 000 elv/day, and the amount of heavies should be less than 15% of the traffic volume. Furthermore their use in high stress areas like climbing lanes and busy intersections should be avoided. The application of modified binders incorporating a cutter on residential streets during cooler temperatures as experienced in the winter months generally presents a low risk of bleeding.

Modified binder seals incorporating up to 3% cutter have been successfully applied on roads carrying relatively high traffic. A reduction in the amount of cutter which would normally be added, as well as a possible reduction in binder application rate, must be made to accommodate the effects of heavier and higher traffic volumes over and above 5 000 elv/day.

Amount of cutter

In the absence of a proven test method to determine the equivalent low temperature adhesion properties of modified binders with cutters, it is recommended that the binder supplier be approached for guidelines on the amount and type of cutter to be used for the respective modified binder in accordance with the expected road temperature.

Construction constraints

The cutting back of modified binders does not negate the need to follow good construction practices. Specific guidelines based on local experience are given in

4. Manufacture

4.1 General

The processes being used to manufacture polymer modified bitumens are proprietary, and different manufacturing configurations and processes are used by the various suppliers. Some aspects are, however, common to all manufacturing processes and the basic requirements for a blending plant for homogenous polymer modified bitumen are:

- Mixing vessels should ideally be heated with hot oil coils, instead of direct flame heating, to minimize the degradation of the polymer at the manufacturing plant. Once on site, flame heating is the norm;
- The heating mechanism should be capable of raising the temperature of the contents of the tank by 5 - 10°C per hour;
- The manufacturing vessels should be fitted with:
 - Calibrated thermometers and temperature controllers;
 - A mixing system which is capable of effectively mixing the polymer into the bitumen;
 - A mechanism for feeding the polymer into the bitumen;
 - A calibrated dipstick.

A general flow diagram for the process of polymer modified bitumen manufacture using a high shear mill is shown in Figure 9.

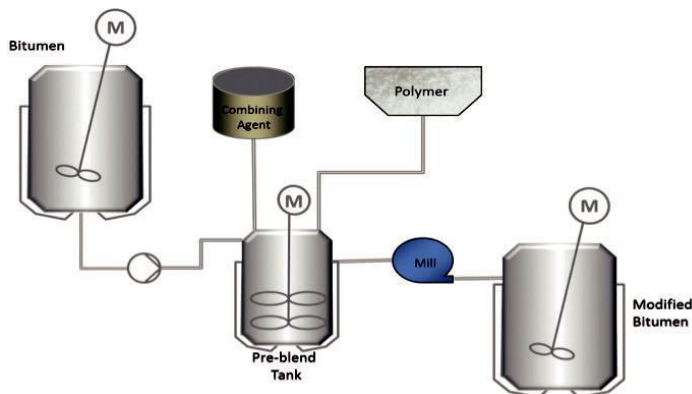

Figure 9: General production process of polymer modified bitumen

The main stages of manufacturing require the following procedures:

- Metering of polymer, bitumen, and additives (combining agents);
- Wetting of the polymer by the bitumen/additive mixture;
- Dispersion of the polymer through the bitumen;
- Interaction (reaction) of the polymer with the bitumen;
- Storage and transportation.

The most important steps in the polymer modified binder manufacturing process are dispersion and reaction. These steps determine the structure (i.e. morphology) of the final binder and hence its properties. Polymer, typically in either: crumb, pellet or powder form, is added to hot bitumen into which the polymer particles disperse. The hot bitumen and additive mixture causes the polymer particles to swell and flow. A number of factors that influence the efficiency of the dispersion process are:

- The polymer particle size - smaller particles present a larger surface area to the bitumen, allowing faster penetration;
- The temperature of the process - bitumen will penetrate the polymer more rapidly at higher temperatures;
- The polymer incorporation system - must be capable of rapidly wetting the polymer and uniformly dispersing it throughout the contents of the vessel;
- The dispersion system – typically a high shear mixer which is required to disperse and dissolve the polymer;
- The type and brand of polymer.

A general overview of the manufacture of the various types of polymer modified binders is given overleaf:

4.2 Homogenous binders

4.2.1 SBR modified bitumen

This type of binder is produced by adding SBR latex, containing approximately 35% water, to hot penetration grade bitumen and, being a liquid, the latex is usually pumped into the hot bitumen. During the addition of the latex, the water component is converted to steam with associated frothing and an increase in the volume of the binder. The addition rate of the latex is carefully controlled to prevent boil-over in the manufacturing vessel. Plants used for the manufacture of the SBR modified binder should be designed in such a way as to enable the steam component to escape from the manufacturing vessel to avoid entrapment of moisture in the binder.

The residual SBR component is dissolved in the bitumen by agitation and pump circulation. The agitation/circulation time and manufacturing temperature required is a function of the polymer/bitumen compatibility, with extended mixing times and higher mixing temperatures being required for less compatible systems.

If the heated product has to be stored in the manufacturing vessel for any reason, it is advisable to agitate or circulate the final product during storage, to prevent possible polymer segregation.

It is important that the water be completely expelled in the manufacturing vessel before discharge. Residual water can cause further foaming during heating in binder distributors and haulier tanks, with the possibility of boil-over.

4.2.2 SBS modified bitumen

SBS polymers are available in pellet, crumb or powder form. If pellet or crumb polymer is used, the manufacturing plant should be fitted with a high speed shearing device that will reduce the suspended polymer particles to a size suitable for easy solubility in the bitumen. SBS in powder form can be incorporated into the binder by simple agitation at the required temperature. The manufacturing temperature and time required for dissolving this polymer is lower than that required for SBR modification. Polymer degradation is thus considerably retarded.

The rate of addition of the polymer to the manufacturing vessel should be carefully controlled. If the addition rate is too high, polymer conglomerates could form on the surface, resulting in lumps, which could be problematic during application of the binder.

Similar to SBR modified bitumen, it is advisable to have some means of circulation in the vessel to prevent possible polymer segregation during storage of the heated binder.

A schematic of a typical mixing process of SBS modified bitumen is given in Figure 10.

4.2.3 RET

Although this type of polymer is in pellet form, high speed shear mills are not required and only agitation is necessary to blend the polymer with the bitumen. After the reaction has taken place, the modified binder is ready for use or shipping to site.

4.2.4 EVA

EVA polymer is incorporated into bitumen by adding the polymer pellets while stirring or circulating the contents of the mixing vessel. The polymer melts in the bitumen and a short period is required for the polymer to dissolve completely. As with SBR and SBS modified bitumen, the compatibility of EVA with the base bitumen should be assessed.

A schematic of a typical mixing process of EVA modified bitumen is given in Figure 10.

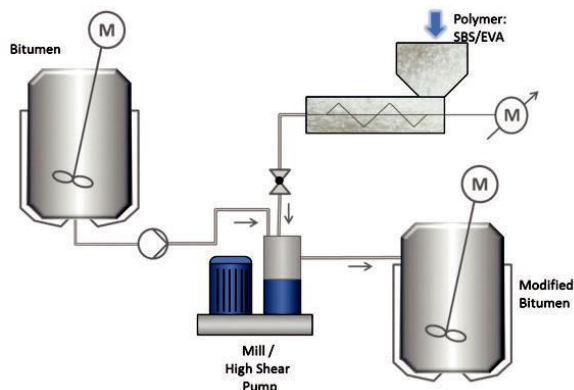

Figure 10: Typical mixing process of SBS and EVA modified bitumen

4.2.5 Hydrocarbon modified binders and high molecular weight waxes

Hydrocarbon modifiers and high molecular weight waxes can be added to the heated bitumen while stirring or circulating the contents of the mixing vessel. The same wetting tank and manufacturing process used with polymers is used for high molecular weight waxes at a manufacturing plant. Similar to EVA, the hydrocarbon modifier dissolves in the bitumen after a short mixing period. No compatibility problems have been found with the modification of locally produced bitumens.

4.3 Non-homogenous polymer modified binder

Bitumen-rubber is manufactured by adding graded crumbed rubber, obtained from grinding vehicle tyres, to hot bitumen which contains a quantity of heavy extender oil. Following the addition of the rubber, a digestion period is required for the rubber to swell and partially dissolve in the bitumen/extender oil blend. The rubber never completely dissolves in the bitumen and the product is thus classed as a non-homogenous binder.

Special manufacturing equipment is required to manufacture this highly viscous material. The product has a limited useable life of 4 - 6 hours, and therefore manufacture usually takes place on site or very close to it.

More recently introduced bitumen rubber technologies may adopt proprietary pre-processing to achieve pre-swelling or warm-mix-technologies to achieve co-mingling of the components in order to attain the desired physical and rheological behaviour in the final product.

When bitumen-rubber binder is used for surfacing seal applications, it is applied with binder distributors specially designed to handle this highly viscous binder. In these applications, the bitumen-rubber binder is manufactured using the "wet-blend method", whereby the rubber is added to and digested by the hot bitumen. Two processes can be employed for the manufacture of bitumen-rubber asphalt: the "wet-blend method" as well as the "dry-blend" method whereby the rubber is added to the aggregate in the same way as filler. The wet-blend method is used in the majority of cases.

4.3.1 The wet method

A typical bitumen-rubber blending unit as shown in Figure 11 consists of:

- a tank for super-heating the bitumen;
- a blending unit;
- a suitable rubber feeding mechanism;
- transfer pumps;
- a digestion tank equipped with an agitator and a super-heater.

The extender oil could either be added to the penetration grade bitumen before delivery, or to the bitumen on site. The bitumen is pumped into the small blending tank at a temperature of not more than 220°C for short periods before the introduction of rubber in proportion to the bitumen flow rate. The blending unit consists of a small tank equipped with a high speed stirring device which ensures proper "wetting" of the rubber, and prevents the formation of rubber lumps in the final product. During the addition of the rubber component, the blend cools down considerably and has to be re-heated to a temperature of 190 - 200°C to ensure proper digestion of the rubber. From the blending tank the product is transferred to a digestion tank which could also be a specialised binder distributor. During the digestion period the product is continually agitated while being heated to the final temperature.

On completion of the digestion period, a hand-held Haake viscometer is used to perform a viscosity test on the product to confirm that sufficient digestion has taken place. If approved, the product is ready for application.

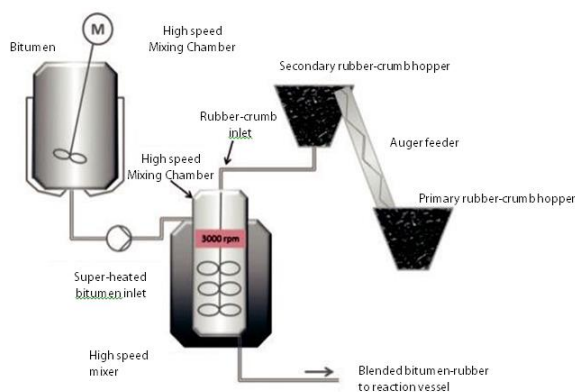

Figure 11: Schematic of a typical high speed bitumen-rubber blender

4.3.2 The dry method

The dry method is only used in conjunction with batch type asphalt mixing plants – not with drum or continuous mixer types. The plant must also be fitted with the necessary equipment to feed accurate quantities of crumbed rubber into the pugmill. The temperature of the aggregate in the pugmill should be within the range 190 – 210°C. The correct quantity of crumbed rubber is added to the hot aggregate in the pugmill and mixed for 5 - 7 seconds, following which the bitumen is added.

Sufficient mixing time should be allowed to ensure acceptable distribution of the bitumen throughout the aggregate/rubber blend. The bitumen temperature should be 145 – 165°C and the asphalt leaving the pugmill should be at a temperature ranging from 190 – 210°C. The mix is then transferred to the hot-storage bins where it is left for at least an hour to allow for the digestion of the rubber by the bitumen. The asphalt is drawn from the bins and transported to site as required.

Practitioners tend to be sceptical of the dry blend method, because of the inability to determine the properties of the bitumen-rubber binder in the mix. Hence the use of this method is generally only justified if small quantities of bitumen-rubber asphalt are required for emergency repairs. The wet blend method usually involves substantial establishment costs of the blending unit, which are only justified for larger projects.

4.4 General items

4.4.1 Combining agents

Combining agents are sometimes added to polymer modified binders to improve their performance and shelf life. Most modified binders are sufficiently stable through normal processing and application temperatures. However, the inclusion of combining agents and other additives, coupled with higher temperatures than normally used with conventional bitumen, can produce a noticeable increase in fuming.

4.4.2 Pre-blending

Where raw materials are required to be pre-blended, procedures should be established and documented for proportioning, mixing and storing the blended material.

4.4.3 Mixing

Component materials should be thoroughly mixed to ensure production of a homogeneous modified binder. The design of mixing equipment varies considerably depending on the type of binder being manufactured. They can vary from high shear mills used to blend SBS pellets, to low shear agitators for blending rubber crumbs. However, critical elements that are common to all processes are procedures for proportioning of materials, temperature control, mixing time and conditions, and maintenance and cleanliness of equipment.

4.4.4 High shear mixers

In these mixers the polymer mixed into the bitumen is ground to finer particles. The size of the particles is influenced by the gap width between the stator and the rotor. Decreasing size increases the specific surface area, speeding up the absorption of the oily components in the bitumen. The absorption of oily components softens the polymer particles, and allows shear forces in the high shear mixer to tear and stretch these particles, further increasing the specific surface area. Eventually this should result in a homogeneous dispersion of the polymer throughout the bitumen.

5. MODIFIED BINDER CLASSIFICATION

The intention of the classification system is to provide a means of selecting a modified binder that does not prescribe the type and concentration of polymer to be used in a particular application. Rather, the classification focuses on performance requirements of the binder.

For this purpose a generic system has been developed for classifying modified binders according to four main criteria based on application type and temperature, type of polymer used, and a numerical value. The following codes are used to designate the different classes of modified binders:

- Type of application:
 - Spray seal (S);
 - Asphalt (A);
 - Crack sealant (C).
- Type of binder system:
 - Emulsion – If the product is an emulsion then the letter C would follow directly after the letter indicating the type of application;
 - Hot applied – No letter is used after the letter indicating the type of application.
- Predominant type of modifier used:
 - Elastomer (E) e.g. A-E1;
 - Plastomer (P) e.g. A-P1;
 - Rubber (R) e.g. S-R1;
 - Hydrocarbon (H) e.g. A-H1.
- Level of modification:

This is indicated by a numerical value. The higher the number the higher the softening point value of the binder, but this does not necessarily imply improved overall performance properties. The intention is to provide for higher order modification in the future, should the need arise, by increasing the numerical value.

An additional code can also be used for classification purposes to indicate whether or not the use of a fluxing agent or cutter is permitted. Should the binder application not permit the use of flux or cutter the letter “t” should be shown in brackets after the classification.

As an example, a classification of SC-E2(t) indicates the following:

- | | |
|------------|--|
| S | The binder is intended to be used in a surfacing seal; |
| C | The binder is an emulsion; |
| E | The main modifier is an elastomer type; |
| 2 | The binder has a higher softening point than an SC-E1; |
| (t) | The use of a fluxing agent or cutter is prohibited. |

Table 4 summarises the different classes of generic modified binders according to their end application.

Table 4: Modified binder classification system

Modified Binder Class	Application – Spray Seal
S-E1	Spray seal – hot applied elastomer modified
S-E2	Spray seal – hot applied elastomer modified
S-R1	Spray seal – hot applied bitumen-rubber
S-R2	Spray seal – hot applied bitumen-rubber
SC-E1 ¹	Spray seal – emulsion elastomer modified
SC-E2 ¹	Spray seal – emulsion elastomer modified
	Application – Premixed Asphalt
A-E1	Asphalt – elastomer modified
A-E2	Asphalt – elastomer modified
A-P1 ²	Asphalt – plastomer modified
A-H1	Asphalt – hydrocarbon modified
A-H2 ²	Asphalt – hydrocarbon modified
A-R1	Asphalt – bitumen-rubber
A-R2	Asphalt – bitumen-rubber
AC – E1	Microsurfacing – emulsion elastomer modified
AC – E2	Microsurfacing – emulsion elastomer modified
	Application – Crack Sealant
C – E1	Crack sealant – hot applied elastomer modified
CC – E1	Crack sealant – emulsion elastomer modified
C – R1	Crack sealant – hot applied bitumen rubber
C – R2	Crack sealant – hot applied bitumen-rubber

Notes

¹ These emulsions have the option of being made with or without cutters depending on their application.

² Some of the modifiers in these classification classes are also capable of imparting fuel resistant properties.

More details pertaining to the selection and properties of these modified binders and their specialist application are covered in Chapter 7.

6 PRODUCT REQUIREMENTS

In developing the product requirements for each generic class of binder an attempt has been made, where possible, to use the same testing regimen with appropriate compliance limits. However, this is not the case for polymer modified binders compared to bitumen-rubber due to the distinct nature of the composition and behaviour of these two binder types.

The tests prescribed in the specification framework have been selected to ensure that:

- The consistency of binders is controlled at the various in-service temperature ranges:
 - Low temperature to limit fatigue cracking (Elastic Recovery @ 15°C)
 - Elevated temperature to limit rutting and bleeding (Ring & Ball Softening Point)
- Modified binders used in road surfacings can be expected to perform over a range of climatic and traffic conditions. The specification framework has been based on a wide range of softening point values to accommodate South Africa's typically hot climate.
- The binder is pumpable (Viscosity @ 165°C), safe (Flash point) and stable (Storage Stability @180°C) during normal handling and storage conditions.
- The performance is within acceptable limits after ageing when subjected to the rolling thin film oven test (RTFOT).

The test limits prescribed are empirically based on observed in-service performance over several years, and reflect current production trends in South Africa. While the ultimate goal is to formulate performance related specifications, the industry is currently not in a position to prescribe tests and associated limits which would render this possible. However, for a given project, it may be necessary to perform additional tests to rank the properties of the various binders in order to reduce risk.

The properties for the various modified binders and their respective applications are given in Tables 5 - 10.

Table 5: Properties of hot applied polymer modified binders for surfacing seals

Property	Unit	Test Method	Class	
Before ageing			S-E1	S-E2
Softening Point	°C	MB-17	50-70	60-80 ¹
Elastic recovery @ 15°C	%	MB-4	>50	>60
Dynamic Viscosity @ 165°C	Pa.s	MB-18	≤0.55	≤0.60
Storage Stability @ 180°C ²	°C	MB-6	≤5	≤5
Flash Point	°C	ASTM D92	≥230	≥230
After ageing (RTFOT)				
Mass change ³	%	MB-3	≤1.0	≤1.0
Elastic recovery @ 15°C	%	MB-4	>50	>60

Notes

¹ The softening point values obtained for bitumen modified with SBS will tend to fluctuate over time and on reheating. Road surfaces could become too rigid at low overnight temperatures with resultant poor adhesion properties.

² Certain base bitumens, when used in the production of modified binders, are prone to cause segregation of the modified binder. The Storage Stability test result should be interpreted as an indicator of the compatibility of the base bitumen and the modifier used. In cases where compliance limits are not met, proposals of site agitation procedures of the binder to prevent segregation shall be submitted to the client for consideration. In all cases whenever there is any reason to believe that the composition of the base bitumen has changed, the test shall be repeated to ensure compliance or to determine the need for measures to prevent segregation

³ Mass loss gives an indication of the presence of volatiles in the binder.

Table 6: Properties of polymer modified emulsions for surfacing seals

Property	Unit	Test Method	Class			
			SC-E1		SC-E2	
Binder content (m/m) ¹	%	MB-22	65-68	70-73	65-68	70-73
Saybolt Furol viscosity @ 50°C	sec	MB-21	51-200	51-400	51-200	51-400
Residue on sieving ² (/100 ml)	710µm sieve	MB-23	≤0.1		≤0.1	
	150µm sieve		≤0.5		≤0.5	
Particle charge		MB-24	positive		positive	
Sedimentation after 60 rotations		SANS 4001 BT3	nil		nil	
Recovered binder residue		MB-20 ³				
Softening point	°C	MB-17	≥48		≥55	
Elastic recovery @ 15°C	%	MB-4	≥50		≥55	

Notes

- 1 For steep inclines, severe cross fall and higher application rates it is advisable to use the higher binder content emulsion to reduce runoff.
- 2 Pour the emulsion through the larger sieve to remove the skin and larger particles before passing the emulsion through the finer sieve.
- 3 Either the rotary vacuum or the simple evaporation method can be used. For on-site testing the simple method is more practical and is thus recommended. The simple method retains most of the fluxing oils whereas these are removed in the rotary vacuum method. The latter method renders a better indication of the binder properties after in-service curing.

Table 7: Properties of polymer modified binders for asphalt

Property	Unit	Test Method	Class		
			A-E1	A-E2	A-P1
Before ageing					
Softening point	°C	MB-17	55-65	65-85	63-73
Elastic recovery @ 15°C	%	MB-4	> 50	> 60	30 - 50
Dynamic viscosity @ 165°C	Pa.s	MB-18	≤0,6	≤0,6	≤0,55
Storage stability @ 180°C ¹	°C	MB-6	≤5	≤5	≤5
Flash point	°C	ASTM D92	≥230	≥230	≥230
After ageing (RTFOT)					
Mass change	%	MB-3	≤1,0	≤1,0	≤1,0
Softening point (min)	°C	MB-17	53	63	61
Elastic recovery @ 15°C	%	MB-4	> 40	> 50	

Note

¹ Certain base bitumens, when used in the production of modified binders, are prone to cause segregation of the modified binder. The Storage Stability test result should be interpreted as an indicator of the compatibility of the base bitumen and the modifier used. In cases where compliance limits are not met, proposals of site agitation procedures of the binder to prevent segregation shall be submitted to the client for consideration. In all cases, whenever there is any reason to believe that the composition of the base bitumen has changed, the test shall be repeated to ensure compliance or to determine the need for measures to prevent segregation.

Care should be taken when changing suppliers of A-E1 and A-E2 modified binders, as the influence of warm mix technology could have a significant influence on the compaction temperature, depending on the source of base bitumen used. It is recommended that a new compaction temperature be established in such cases by compacting at different temperatures. The compaction temperature that matches the void content of the original mix design should then be used. The suppliers of modified binders must inform their clients of the presence of warm mix technology products in their binder.

Table 8: Properties of bitumen-rubber for chip seals and asphalt

Property	Unit	Test Method	Bitumen-rubber Class			
			A-R1	S-R1	A-R2	S-R2
Softening Point	°C	MB-17	55 – 65	55 – 65	65 – 80	65 – 80
Dynamic viscosity at 190°C	dPa.s	MB-13	20 – 50	20 – 40	-	-
Dynamic viscosity at 170°C			-	-	10 – 40	10 – 40
Compression Recovery	5 minutes	MB-11	> 80	> 70	> 70	> 70
	1 hour		> 70	> 70	> 70	> 70
	24 hours		n/a	> 40	n/a	> 25
Resilience at 25°C	%	MB-10	13 – 40	13 – 35	10 – 40	10 – 40
Flow at 60°C	mm	MB-12	10 – 50	15 – 70	0 – 40	0 – 40

Table 9: Properties of hydrocarbon modified binders for asphalt

Property	Unit	Test method	Class	
Before Ageing			A-H1	A-H2
Softening point	°C	MB-17	55-70	70-90
Penetration @ 25°C	dmm	EN1426	20-35	
Dynamic viscosity @ 165°C	Pa.s	MB-18	≤0.80	≤0.30
Storage stability @ 180° C ¹	°C	MB-6	≤5	≤5
Flash point	°C	ASTM D92	≥230	≥230
After ageing (RTFOT)				
Mass change	%	MB-3	≤1.0	≤1.0
Difference in softening point	°C	MB-17	-2 to +8	2 to +8
Retained penetration (% of original)	%	EN1426	> 60	

¹ Certain bitumens, when used in the production of modified binders, are prone to cause segregation of the modified binder. The Storage Stability test result should be interpreted as an indicator of the compatibility of the base bitumen and the modifier used. In cases where compliance limits are not met, proposals of site agitation procedures of the binder to prevent segregation shall be submitted to the client for

consideration. In all cases whenever there is any reason to believe that the composition of the base bitumen has changed, the test shall be repeated to ensure compliance or to determine the need for measures to prevent segregation.

Table 10: Properties of modified binder crack sealants

Property	Unit	Test Method	Class			
			C-E1	CC-E1 ¹	C-R1	C-R2
Softening point	°C	MB-17	≥80	≥70 ²	55-65	
Elastic recovery @ 15°C	%	MB-4	≥80	≥50 ²	-	
Dynamic viscosity @ 190°C	dPa.s	MB-13	-	-	20-40	
Dynamic viscosity @ 170°C	dPa.s	MB-13				10-40
Dynamic viscosity @ 165°C	Pa.s	MB-18	≤0,65	-	-	
Dynamic viscosity @ 25°C	Pa.s	MB-18	-	≤0.8	-	
Resilience @ 25°C	%	MB-10	-	-	13-40	10-40
Flow	mm	MB-12	-	-	15-70	0-40
Binder content (m/m)	%	MB-22	-	≥55	-	-

Notes

¹ CC-E1 is suitable for 2 - 4 mm cracks. For wider cracks use C-E1, C-R1 or CR-2

² Value to be determined on the residue after recovery of the binder by evaporation method MB-20.

6.1 Special applications

Some modified binders are used in special applications where the properties or product requirements are not covered under the generic classification. This section deals with such specialist applications, and recommendations are made based on proven experience as observed in the field after many years of performance in South Africa.

6.1.1 Modified emulsions for microsurfacing

The use of rubber latex modified emulsions in the application of microsurfacing for overlays and rut-filling of existing bituminous surfaces has been common practice in South Africa since the early 1980's. The use of an elastomeric modified emulsion in microsurfacing yields advantages over conventional slurry seals in that microsurfacing can be applied in greater thicknesses in a single pass, and the surface texture is maintained for a longer period due to improved binder cohesion and temperature susceptibility.

Emulsions used in conventional slurries are manufactured from 70/100 bitumen, which has a minimum softening point of only 42°C. The addition of an elastomer improves the adhesion of the binder to the aggregate, thus reducing the loss of aggregate, especially in the early life of the seal. In the case of rut-filling, the elastomer, in conjunction with a harder grade of base bitumen, will increase the consistency of the binder at high in-service temperatures and thus increase the rut resistance of the mix. It must be noted that the elastomer component in the mixture is not sufficient to prevent reflective cracking in the new surface.

The recommended limits given in Table 11 are for a quickset cationic bitumen emulsion modified with an elastomer which is used with a continuously graded crusher dust and applied by a continuously mixing machine. The emulsion must be specially formulated to allow for a period of between 90 and 120 seconds when mixed with the selected aggregate, to ensure sufficient setting time of the mix during placing.

Table 11: Properties of polymer modified emulsions for machine- applied microsurfacing

Property		Unit	Test Method	Class	
				AC-E1 (Overlay)	AC-E2 (Rut filling)
Binder content (m/m)		%	MB-22	62-65	62-65
Residue on sieving ¹ (/100 ml)	710µm sieve	G	MB-23	≤0,1	≤0,1
	150µm sieve			≤0,5	≤0,5
Particle charge			MB-24	positive	positive
Sedimentation after 60 rotations			SANS 4001 BT3	nil	nil
Recovered binder residue			MB-20 ²		
Softening point		°C	MB-17	≥48	
Elastic recovery @ 15°C		%	MB-4	≥50	

Notes

- ¹ Pour the emulsion through the larger sieve to remove the skin and larger particles before passing the emulsion through the finer sieve.
- ² Either the rotary vacuum or the simple evaporation method can be used. For on-site testing the simple method is more practical and is thus recommended. The simple method retains the fluxing oils whereas these are removed in the rotary vacuum method. The latter method renders a better indication of the binder properties after in-service curing.

6.1.2 Hydrocarbon modified bitumen for high modulus asphalt

Where it is the aim to achieve high stiffness modulus asphalt mixes for heavy traffic loading such as will occur on climbing lanes and busy intersections, the addition of naturally occurring hydrocarbon to the binder can be considered to increase the hardness of the resultant modified binder.

Additionally, the raised softening point and viscosity at elevated service temperature of hydrocarbon modified binders will improve the deformation resistance of asphalt mixes compared to those manufactured with conventional penetration grade bitumen. The use of hydrocarbon modified binders should be considered as a cost effective way to improve the rut resistance of asphalt bases and wearing courses in hot climates. The use of hydrocarbon modified mixes is not recommended in pavements with high deflections.

The properties recommended for hydrocarbon modified binders for use in high modulus asphalt are shown in Table 9.

6.1.3 Modified binders for fuel resistant surfacings

Bituminous binders are soluble in petroleum solvents and all bituminous surfacings are therefore susceptible to damage from spillages of diesel, petrol and solvents. However some modifiers can improve the fuel resistant properties of bituminous mixes. Asphalt surfaces used in areas such as climbing lanes, busy intersections, bus depots, toll plazas or airport aprons are more prone to damage from fuel spillage. In such situations, where there is a high risk of fuel spillage, the use of a binder with fuel resistant properties such as A-P1 (modified with EVA) is recommended.

Tests have been developed for measuring the fuel resistant properties of asphalt mixes. Two standards are in use in Europe, one being EN 12697-43 and the other the French standard NF P 98-251-1. The EN standard involves soaking the asphalt briquette in fuel for a period followed by brushing in a Hobart mixer. The material loss of the briquette is a measure of the resistance of the asphalt to fuel. The French method is based on the Duriez test and involves soaking an asphalt briquette in kerosene for 7 days and comparing the dry strength to the soaked strength similarly to the immersion index for adhesion.

When requesting a fuel resistant binder for asphalt wearing course, it is recommended that the supplier quantifies the fuel resistant properties of the binder in accordance with these two standards in terms of percentage mass loss or loss of strength. This will provide a tool to rank the fuel resistance of the different binders along with the other performance parameters being considered for the project.

6.1.4 Modified bitumen emulsion for tack coat

Ultra-thin open graded asphalt layers are usually placed with integrated pavers/sprayers that are capable of applying a tack coat prior to placing the asphalt layer. Because the shearing forces acting on the interface between the substrate and the asphalt overlay are much higher than those experienced with thicker asphalt layers, it is necessary to modify the emulsion

with polymer to improve the bond strength at the interface.

In cases where pick-up of the tack coat may occur, e.g. by trucks or asphalt pavers, it would be necessary to use a special polymer modified emulsion, known as "trackless tack". These emulsions are characterised by having rapid setting characteristics, and the residue deposited on the road surface is less tacky than the residue obtained from conventional tack coat emulsions.

The emulsion must be formulated to enable it to be applied through a spray bar positioned on the asphalt paver, immediately preceding the placing of the asphalt. The properties of the residual binder are enhanced by the elastomer, while the viscosity of the emulsion should be low enough to allow the product to be easily sprayed. The enhanced binder consistency must be such as to minimise the migration of the binder into the new thin layer to prevent flushing and the subsequent closing up of the surface texture under traffic. The elastomer also helps improve the adhesion of the new thin layer to the existing substrate under severe traffic action.

The properties of a modified emulsion used as a tack coat for UTFs are similar to those for SC-E1 (65-68% binder content) shown in Table 6, which outlines the properties for polymer modified emulsions for surfacing seals.

It must, however, be noted that the following requirements should be taken into consideration:

- No cutter may be used in the formulation of the emulsion, as this will lead to solvent entrapment in the new surface, increasing the risk of bleeding;
- The viscosity requirements are lower (i.e. 21-100 SFs @ 50°C) given the need for the emulsion to be sprayed at lower application rates and to be able to flow more readily on application.

6.1.5 Modified emulsions for geotextile application

Cracked surfaces are often covered with special geotextile membranes bonded with latex modified emulsions. The addition of the latex ensures that the emulsion residue is tenacious, and thus prevents slippage of the thin geotextile membrane.

7. SELECTION CRITERIA

Modified binders are more expensive than conventional binders. The decision to utilise a modified binder should therefore always be made on the basis of “value engineering” and not “fashion”. However, the cost premium of utilising these binders can frequently be justified by improved performance and/or extended service life of the constructed layer. Table 12 provides a guideline to the advantages and disadvantages of modified binders compared with conventional binders to assist in the selection process.

Table 12: Advantages and disadvantages of modified binders compared with conventional binders

Binder type	Advantages	Disadvantages
Penetration grade (70/100)	<ul style="list-style-type: none"> • Lowest cost binder • Permits small quantities to be ordered • Can be hand sprayed • Allows trapped water vapour to escape • Good aggregate wetting • Has “self-healing” characteristics 	<ul style="list-style-type: none"> • Can flush/bleed as a result of high road surface temperatures • Can flush/bleed as a result of heavy traffic loading • Can result in a too low application rate in cases of heavy traffic loading
SE-1 (SBR, RET)	<ul style="list-style-type: none"> • Reduced temperature susceptibility • High viscosity at maximum in-service temperature reduces risk of bleeding • Increased cohesive strength 	<ul style="list-style-type: none"> • Increased binder cost • Limited storage life at application temperature • Can restrict evaporation of entrapped moisture • Difficult to hand spray
SE-2 (SBS, RET)	<ul style="list-style-type: none"> • Increased cohesion under heavy traffic loading due to high elastic recovery • High softening point reduces risk of bleeding as a result of high road surface temperatures • Lower application temperature than SBR and BR 	<ul style="list-style-type: none"> • Increased binder cost • Early binder/aggregate adhesion sensitive to cold ambient temperatures and/or moisture • Requires aggregate to be pre-coated
Bitumen-rubber	<ul style="list-style-type: none"> • Permits higher application rates without risk of bleeding • Increased viscosity at service temperatures reduces risk of bleeding • Permits higher application rates without risk of bleeding • Improved ageing resistance due to carbon black content • Ideal for sealing a surface with cracks (< 3,0 mm) • Suitable for constructing a SAMI 	<ul style="list-style-type: none"> • Highest surfacing cost • Requires special distributors with augers for application • Difficult to hand spray • Difficult to produce in small quantities • Limited storage life at application temperature ¹ • Does restrict evaporation of entrapped moisture • Early binder/aggregate adhesion sensitive to cold temperatures and/or moisture • Requires aggregate to be pre-coated

¹ Storage life of hot bitumen-rubber binders conforming to the requirements of S-R2, A-R2 and C-R2 do not present significant limitations as handling and applications temperatures are significantly reduced.

The characteristics and behaviour of modified bitumen can differ significantly from that of conventional bitumen. As discussed in Chapter 3, they are generally more viscous, cohesive and resilient, which can influence, to a greater or lesser degree, aspects such as surfacing seal and/or asphalt design procedures, handling and storage of the binder, climatic condition limitations during construction, as well as construction techniques and limitations.

Experience has shown that modified binders are very sensitive to poor aggregate/binder adhesion immediately after construction, and if extreme climatic conditions are expected, the use of such products must be selected with caution. Thus, the simple substitution of conventional bitumen with a modified product, without taking aspects such as the above into account, will probably result in sub-optimal performance and possibly premature failure.

The selection of modified binders should thus always be based on specific needs and particular constraints and should never be regarded as a substitute for good design and construction practice.

Modified binders have been classified according to the application in which they are expected to perform. Some recommendations on the most appropriate product for a given primary in-service requirement, substrate condition and/or component availability are given below. Also highlighted are some constraints related to the use of these products.

When the field conditions or demands are such that none of the selection criteria necessarily apply, specialist advice needs to be obtained.

7.1 Spray Seal Applications

The primary function of a seal is one, or more, of the following:

- Provision (or reinstatement) of a safe riding surface (macro texture);
- Prevention of ingress of moisture into the structural support layers;
- Protecting an aged existing bituminous surfacing;
- Limiting the reflection of fine to medium cracks due to either distress in a substrate or environmental influences on the surface through the use of Stress Absorbing Membranes (SAM) or Stress Absorbing Membrane Interlayers (SAMI).

With the exception of SAM or SAMI layers, it could be argued that the use of conventional bitumen would be appropriate in the majority of surfacing seal applications in South Africa. However, the sustained increase in traffic volumes, as well as loading spectrum on some routes, results in many instances where the historically proven performance range of conventional binders is being exceeded. Thus, in many instances the use of modified binders could extend the range with respect to the appropriateness of surfacing seal applications as a result of:

- Increased binder application rate (for early aggregate retention);
- Increased binder application rate (to improve impermeability);
- Improved shear strength for high stress situations e.g. turning traffic;
- Reduced risk of bleeding (increased binder cohesion) under high in-service temperature conditions (>60°C);
- Reduced sensitivity to daily fluctuations of in-service temperatures;
- Limiting, or delaying, reflective or thermal cracking;
- Increased durability (increased binder film thickness).

It should however be noted that the binder is only one element of a surfacing seal system, and that all aspects such as climate, aggregate, design and construction must be considered prior to selecting the most appropriate binder.

7.1.1 Environmental influences during application

Due to the increased viscosity and cohesive properties of modified binders, the climatic conditions required during their application are far more restrictive when compared to those for conventional hot applied binders. An increase in binder cohesion usually results in a corresponding decrease in adhesion (ability to retain aggregate). Due to this reduction in aggregate wetting property, aggregate loss is a real risk if rain or very cold and/or windy conditions are experienced soon after construction. This can be particularly problematic on spray seals having a relatively low binder application rate as a result of a high traffic loading profile.

The risk of early, and sometimes catastrophic, aggregate loss can be reduced by considering some of the following measures:

- **Seal type:** single seals are the most vulnerable, especially those with larger ALD aggregates (i.e. 19 mm versus 6.7 mm). The use of double seals significantly reduces the risk of aggregate loss by improving the aggregate interlock;
- **Cover sprays:** the application of a diluted/undiluted cationic spray grade emulsion can reduce the risk even further as the binder helps glue the aggregates together. The use of conventional binder for the second spray of the double seal could also be considered;

- **Delay in trafficking:** local experience has shown that a significant reduction in early aggregate loss can be achieved if traffic is kept off the newly constructed seal for 24 - 48 hours. Continuous rolling and brooming, especially during the warmer period of the following day or two, is however necessary to achieve this reduction in aggregate loss;
- **Adhesion agent:** it is becoming standard practice to add an adhesion agent to the binder to improve its aggregate wetting and/or adhesion properties. Unless the stability (and thus effectiveness) of the product has been adequately proven, the adhesion agent should only be added immediately prior to spraying (up to 30 minutes), typically at a rate of 0.3 - 0.5% v/v) and circulated in the spray tanker;
- **Road surface temperature:** the minimum surface temperatures for surfacing sealing with the respective modified binders are given in Table 13 as a guideline;
- **Cutting back:** while the addition of a cutter may solve, or reduce, a potential adhesion problem in the short term, problems have been experienced with respect to bleeding/flushing of the surface during subsequent hot periods, especially in heavy duty applications. This practice should only be considered when spraying at the end of the summer season before the onset of winter. The use of cut-back modified binders (winter-grades) has, however, been successful in relatively light duty applications, such as residential streets. Refer to Chapter 3 for information covering the procedures and performance risks associated with this practice.

Table 13: Minimum road surface temperatures for surface sealing

Binder Class	Minimum road surface temp (°C) ¹
S-E1; S-E2	25
SC-E1; SC-E2	10
S-R1; S-R2	25

Note

¹ The supplier's method statement should also be noted.

7.1.2 Aggregate influences

The following factors relating to the aggregates being used should be considered when selecting an appropriate binder:

- **Aggregate quality:** Due to the reduction in the wetting characteristics of modified binders, it is important to use aggregate of good quality that is dry and free from dust. It may therefore be necessary to cover the aggregate stockpiles if rain is expected during the construction period. These conditions apply to all hot applied modified seals, including those applied on lower traffic volume roads. Where the above condition cannot be guaranteed, consideration should be given to utilising cold applied modified binders (emulsions) which are generally more accommodating with respect to aggregate cleanliness and moisture conditions;
- **Pre-coating:** In all instances of hot applied modified binders it is recommended that the aggregate should be pre-coated using a bituminous based pre-coating fluid, containing at least 0.5% adhesion agent, to improve both initial and long term retention of the aggregate. Pre-coating the surfacing aggregate will improve binder/aggregate adhesion by reducing the surface tension between the two interfaces (refer to Sabita Manual 26: *Interim guidelines for primes and stone pre-coating fluids* for more information on best practices for pre-coating aggregates). The application of a final diluted emulsion cover spray may however permit the use of uncoated aggregate in the second application;
- **Aggregate size:** In general, most of the seal types listed in TRH3: *Design and construction of surfacing seals* can be constructed utilising modified binders. Cognisance should however, always be taken of the minimum spray rates applicable to a specific binder. For example, the minimum recommended spray rate for S-R1 and SR2 (bitumen-rubber) binder is 1,8 l/m². To accommodate this minimum application rate, the minimum nominal aggregate size would be in the order of 13mm (ALD >8,0 mm). It may therefore be entirely inappropriate to specify say a 9,5 mm single seal utilising S-R1 or S-R2 binder. Similarly, extreme caution should be exercised if a large nominal aggregate size seal utilising

SC-E1 or SC-E2 binders are specified in areas of steep inclines and/or high superelevation. The required application rates may be such that significant run-off of the binder could occur prior to the application of the aggregate.

7.1.3 Substrate influences

The condition of the substrate will greatly influence the performance of a surfacing seal and, as such, it is important to carry out pre-treatment (to a greater or lesser degree) prior to constructing the seal. The pre-treatment must be carried out to allow sufficient time for curing to take place prior to resealing.

In some instances, however, there may be insufficient funding to implement the most appropriate, though costly, intervention strategy for a long term solution. In such cases the use of modified binders in seals constructed as a temporary holding action is an option that

may be utilised to reduce the rate of deterioration of the pavement and/or its functional properties.

Some of the more common situations encountered are:

- **Aged surfaces:** to ensure good adhesion (both short and long term) to the substrate in situations where the existing surface is still intact but exhibiting signs of ageing or porosity, it may be necessary to apply a light emulsion fog spray to the existing surface prior to application of the modified binder surfacing seal, especially where S-E2 or S-R1 binders are to be used. The resealing of a severely aged, brittle or cracked surface is not recommended unless it is intended as a very short term holding action. The use of a rejuvenator spray can also be considered if the substrate is an open textured seal;
- **Cracked surfaces:** it is important to identify the origin and assess the behaviour of existing cracks on the substrate prior to selecting the most appropriate binder. Surface cracks may be categorised in terms of crack activity (rate of movement) and crack severity (width and depth). The following matters should be considered when dealing with cracked surfaces:
 - Traffic induced cracking (e.g. fatigue) can generally be categorised as rapid crack activity. In these circumstances, a seal design incorporating high binder application rates is recommended and, as such, bitumen-rubber (traditionally S-R1, but now also S-R2) is preferred in such applications. Where the degree of crack activity and structural support are such that significant pumping of fines from the underlying layers is evident, it is unlikely that the application of a modified seal will address the situation other than for a very limited period;
 - Cracking as a result of environmental influences e.g. thermal effects or drying shrinkage (of stabilised layers) can generally be categorised as slow activity cracking. In these instances it would be preferable to use lightly modified, or even unmodified, binders, which have a greater ability to self-heal, than to use highly modified products. If, however, these slow activity cracks also exhibit rapid movement under traffic (i.e. movement across the crack) it may be appropriate to utilise a more highly modified binder;
 - For a stress absorbing membrane interlayer (SAMI) a relatively thick layer of binder is required to dissipate any crack induced strains. In these applications bitumen-rubber (traditionally S-R1, but now also S-R2) is commonly used. However, S-E2 binder may also be adequate in certain situations;
 - All cracks in excess of 3,0 mm in width must be sealed with a C-E1, C-R1 or C-R2 binder or, if wider than 5 mm, be repaired prior to resealing as no modified binder seal can perform satisfactorily in the long term in such situations.
- **Retained moisture:** where the surface to be sealed is cracked or open textured, and there is a likelihood of excess moisture within the layer, the use of a highly modified binder in any resealing application should be viewed with extreme caution. Due to their high cohesion properties, highly modified binders do not permit the escape of any moisture entrapped below the seal, resulting in fairly rapid stripping of the binder from the aggregate in the underlying layer – the so called “pressure cooker effect”. This is especially prevalent where the substrate consists of an asphalt layer. Stripping of the binder has also been observed where the substrate is a surface seal overlying a granular base, but it would appear that the rate of stripping occurs at a slower rate, probably as a result of the thicker binder film prevalent in seals. In such circumstances it would be preferable to apply the seal only after a prolonged dry period. If this is not possible consideration should be given to utilising an unmodified binder which permits the release of moisture and then has the ability to “self-heal” during the warmer periods once the pressure of the water vapour has dissipated.

7.1.4 Project location and programming influences

Hot modified binders degrade or become unstable at a faster rate than conventional binders when heated during storage. In this regard, bitumen rubber (S-R1, S-R2) has a particularly short application window at application temperatures. While re-constitution of modified binders is possible in some circumstances and under certain conditions, it is always preferable to utilise a “fresh” product, thereby removing any possible doubt with respect to compromised performance.

Therefore, the selection of the most appropriate modified binder type should always take into account the following:

- Distance from blending plant;
- Whether the quantity required is sufficient to justify an on-site blending plant;
- The effect of possible delays in application due to variable weather patterns or construction delays;
- The quantity of binder required to be applied on a daily basis;
- Any other practicalities and logistics that would require extended storage time of the product which may possibly compromise its properties;
- Whether the seal will be constructed in winter.

Where any of the above situations are pertinent, consideration should be given to the utilisation of an appropriate modified emulsion binder class.

7.1.5 Traffic influences

The most critical factors generally affecting the performance of a seal are the applied stresses as a result of traffic loading, especially on steep gradients as well as sharp curves. In high traffic situations the maximum conventional binder application rate to prevent bleeding is often lower than the minimum required for retention of the aggregate. Modified binders permit an increase in the application rate without necessarily increasing the risk of bleeding. Thus, the use of modified binders has permitted the successful application of surfacing seals for traffic classes well in excess of those traditionally accepted as being the upper limit using conventional binders.

TRH3: *Design and construction of surfacing seals* provides guidance for the selection of the most appropriate binders for given traffic and climatic conditions. Table 14 provides additional guidelines for the selection of the most appropriate binder for a given stress condition.

The definitions of stress conditions are as follows:

- Highly stressed areas are one or more of the following;
 - >30 000 elv/lane/day (TRH3 classification);
 - Curve radii <50 m;
 - Gradients >5%;
- Moderately stressed areas are one or more of the following:
 - 10 000 to 30 000 elv/lane/day;
 - Curve radii <100 m;
 - Gradients <5%.

Table 14: Selection criteria for surface seals

Condition					
	S-E1	S-E2	SC-E1	SC-E2	S-R1, S-R2
Moderately stressed areas	✓		✓ ¹		
Highly stressed areas		✓		✓ ¹	✓
Steep gradients	✓	✓			✓
Active cracking SAM		✓		✓	✓
Passive cracking SAM	✓		✓		
Active and passive cracking SAM		✓		✓	✓
Active and/or passive cracking SAMI		✓			✓
Entrapped moisture	✓ ²		✓ ²		
Very high road surface temperatures (>60°C)		✓		✓	✓
Low temperature during application (<10°C)		³	✓ ⁴	✓ ⁴	

Notes

¹ Suitable for new construction or reseal projects where traffic accommodation is not a problem.

² Where there is a high risk of moisture entrapment (especially in underlying asphalt layers) the use of an unmodified binder should be considered.

³ A number of cases have been reported where early cracking or crack reflection has been attributed to the sensitivity of S-E2 to cold temperatures.

⁴ Where other factors responsible for possible degradation of the heated product could occur such as long haul distances from the blending plant, disruptions to construction or small areas to be sealed over consecutive days, unmodified binder should also be considered.

7.1.6 Design influences

Modified binders cannot simply be applied at rates determined for conventional binders. Experience and assessment of the performance of modified binder seals over recent years has led to a refinement in the adjustment factors relative to a specific modified binder class. Designers should refer to the latest edition of TRH3: *Design and construction of surfacing seals* for the appropriate design procedures.

7.1.7 Selection guide

Table 14 shows possible applications for a given situation to assist in selecting an appropriate modified binder class. The table does not identify the optimum product as this should only be selected by the practitioner after having taken all relevant factors into account.

7.2 Asphalt

7.2.1 Hot mix asphalt

Not all bituminous binders for hot-mix asphalt (HMA) require modification. The addition of modifiers and other additives is dictated by technical objectives that need to be met. These could include:

- Obtaining stiffer mixes at high service temperatures to minimise rutting;
- Improving fatigue resistance of HMA;
- Improving binder-aggregate bonding to reduce stripping or moisture susceptibility;
- Improving abrasion resistance of HMA to reduce ravelling (particularly in open graded mixes);
- Minimising tender mix problems during construction;
- Rejuvenating aged binders;
- Permitting higher binder film thicknesses for increased mix durability;
- Preventing binder segregation in discontinuous gradings (e.g. stone-mastic asphalt);
- Reducing flushing and bleeding;
- Improving resistance to ageing or oxidation;
- Reducing structural thickness of pavement layers (based on expert opinion);
- Reducing life-cycle costs of flexible pavements surfaced with HMA;
- Improving fuel resistance (modifier dependant).

The decision whether to incorporate a modifier or additive in an HMA mixture, and if so, what class, should always be based on expert analysis of service conditions and/or fundamental engineering requirements such as:

- Predicted spectrum of traffic loading;
- Predicted in-service pavement temperatures that will influence the risk for rutting or low temperature fracture;
- Stiffness or resilience of the substrate;
- Degree and extent of existing distresses prior to rehabilitation;
- Generic type of mix selected e.g. stone or sand skeleton.

The incorporation of modifiers or additives into HMA may improve the performance characteristics of the layer and enhance the durability of the mix, which ultimately may result in an extended service life and reduced maintenance. It is, however, important to recognise that the incorporation of a modifier or additive is only part of the process of improving the performance of HMA; the aggregate packing configuration is another.

Although each modifier or additive may offer certain benefits over conventional binders, there are no universal solutions to the challenges posed. Sometimes, one property of HMA is improved, but at the expense of another. At any time one should ensure that proper practice is followed in pavement/mix design and construction procedures. Then, and only then, should one consider how engineering the binder will address the design objectives. Table 15 lists some common binder modifiers and additives used in HMA and the general purpose of their use:

Table 15: Common binder modifiers and additives used in asphalt

Type	General purpose	Generic examples
Filler	<p>Fills voids and therefore reduces optimum binder content;</p> <p>Used to satisfy grading requirements;</p> <p>Improves stability;</p> <p>Improves binder-aggregate bond (e.g. lime).</p>	<p>Mineral filler</p> <p>Crushed fines;</p> <p>Portland cement;</p> <p>Lime;</p> <p>Fly ash.</p> <p>Carbon black</p>
Extender	<p>Substitutes a portion of bitumen to decrease the amount of bitumen and/or polymer required;</p> <p>Improves the storage stability of SBS modified binders.</p>	<p>Sulphur</p>
Elastomer	<p>Increases HMA stiffness at high temperatures;</p> <p>Produces a more elastic HMA to resist fatigue cracking at intermediate temperatures;</p> <p>Lower stiffness at low service temperatures to resist thermal cracking.</p>	<p>Styrene-butadiene (SBR);</p> <p>Rubber latex;</p> <p>Styrene-butadiene-styrene (SBS);</p> <p>Styrene-isoprene-styrene (SIS);</p> <p>Crumb rubber; and/ or rubber compounds.</p>
Plastomer	<p>Improves resistance to permanent deformation;</p> <p>Some grades are known to also improve workability.</p>	<p>Ethylene-vinyl-acetate (EVA)</p>
Fibre	<p>Reinforcing and improving the tensile strength and cohesion in HMA;</p> <p>Allows higher binder contents to be used with reduced risk of binder drain-down (open-graded asphalt and SMA);</p> <p>Improves durability due to greater binder film thicknesses.</p>	<p>Natural Rock wool;</p> <p>Polypropylene;</p> <p>Polyester;</p> <p>Fibreglass;</p> <p>Mineral Cellulose.</p>
Warm-mix additives (see 7.2.2)	<p>Improves durability and ease of handling through reduced storage and handling temperatures</p>	<p>FT wax and similar high molecular weight saturate organic components</p>
Antioxidant	<p>Increases the durability of HMA by retarding oxidation</p>	<p>Carbon black</p>

Table 15: (continued)

Type	General purpose	Generic examples
Rejuvenator	Restoration of aged binder	Extender oils
Hydrocarbon	Increases HMA stiffness and resistance to permanent deformation	Natural occurring asphalts, Refinery produced hardening agents (Propane Deasphalted Tar)
Antistripping agents	Minimises stripping of binder from aggregate	Amines Lime
Workability improvement	Reduces mixing and compaction temperature of HMA	FT wax
Fuel resistance	Improves the resistance of the HMA to fuel spillages	FT wax EVA (select grades only)

7.2.1.1 Resistance to permanent deformation (rutting)

The improvement to rut resistant properties of an HMA mix resulting from the incorporation of a modified binder is well documented and widely accepted. This is especially true for sand-skeletal mixes. However, notwithstanding the above, the need to comply fully with all the other fundamental mix design criteria, especially the volumetric properties, cannot be over emphasised.

As implied by the binder classification, binders conforming to the A-P class requirements have been formulated specifically to enhance the rut resistance properties of asphalt. The use of this class of binder should however be restricted to layers constructed

Class A-E binders have to date been the predominant binders used in HMA modification. Notwithstanding the fact that they are classed as “elastomers” their increased stiffness at elevated temperatures can contribute to the rut resistant properties of the mix. In addition, their use is more appropriate on support structures that are more flexible than those preferred for the A-P Class.

Class A-R binders also contribute to deformation resistance and have the added benefit of significantly improving fatigue properties. However, their use is generally restricted to open or semi-open graded mix types, which may not be appropriate on substrate layers that are permeable or aged and sensitive to the ingress of moisture, unless the mix, in the case of a semi-open grading, can be rendered virtually impermeable by the use of a fairly high percentage of A-R binder.

7.2.1.2 Cracking

Cracking in asphalt can be due to one or more of the following:

- Fatigue;
- Shrinkage;
- Environmental.

Fatigue cracking occurs due the cumulative effect of repeated traffic loading, particularly when the stiffness of substrates is low or has been reduced. Modified binders can be effective in increasing the fatigue resistance of HMA for a given strain level.

However, if the strain levels are too high it is doubtful whether any binder class would be effective. In such cases, a surface dressing manufactured with a modified binder (typically an A-R class) could be considered as a holding action.

Shrinkage cracking as a result of seasonal moisture changes and/or cementitious stabilisation can vary greatly with respect to the degree of strain and activity. The use of A-E and A-P class binders in dense graded mixes has proven to be generally ineffective in reducing reflection cracking. Mix types that permit relatively high quantities of modified binder such as SMA and semi-open graded mixes have been used successfully in certain instances. In low volume applications the use of mixes incorporating softer standard bitumen, as well as higher bitumen contents, would also reduce reflection cracking, but resistance to permanent deformation could, as a consequence, be significantly compromised particularly in sand skeleton mixes.

Environmental cracking (top down) occurs as a result of binder ageing and/or temperature changes such as freeze-thaw. The use of modified binders generally permits higher binder film thickness in the mix with a resultant reduction in the risk of premature ageing. Where an existing asphalt surface exhibits signs of ageing it may be necessary to pre-treat the surface (e.g. fog spray) to ensure an adequate bond with the new modified HMA overlay.

7.2.1.3 Mix type

For certain mix types such as SMA and open-grade mixes, the use of a modified binder may be appropriate for purposes other

than improvement to rutting or fatigue resistance properties. For example, they could be used to prevent drain down of the binder during transportation and placing. The use of these binders may replace, or be used together with, other products, such as cellulose fibre.

7.2.1.4 Design criteria

The design of asphalt mixes incorporating modified binders should follow the standard procedures currently in use. Due to the non-Newtonian behaviour of modified binders, selection of appropriate mixing and compaction temperatures requires careful consideration. Incorrect selection of these criteria will result in erroneous determination of the volumetric properties of the mix which are critical quality control elements. Due to the reduced workability resulting from the addition of certain types of modifiers, for a given binder content, modified binders may cause an increase of the voids in mix of between 0.2 and 0.4% above that obtained for standard bitumen.

7.2.1.5 Production criteria

All modified binders have a limited shelf life. This has traditionally been true for the A-R class of binder maintained at application temperatures. Recent developments in this technology have, however, enabled the periods of stability of the mix to be extended. Such products are, however, still currently "proprietary" in nature, and as such, are not covered in this publication.

The logistic issues surrounding the use of modified binders, (e.g. blending and storing) should always be taken into account prior to their selection. Where only small quantities of HMA are required, or where daily production requirements are relatively low, the appropriateness of their use from a cost premium perspective should be carefully considered. In such instances, modified binders with a high storage stability or modifiers that can be incorporated directly into the mixer's pugmill or bitumen feed pipe (i.e. do not require pre-blending with the bitumen) should be considered.

7.2.2 Warm mix asphalt

Warm mix asphalt (WMA) is manufactured and paved at significantly lower temperatures than conventional HMA, while aiming to attain or even exceed the quality of conventional HMA mixes. Generally, WMA is regarded as having production temperatures at least 20°C below those of HMA, but above 100°C. While HMA is generally manufactured at temperatures between 140°C and 160°C, WMA is typically produced at temperatures between 100°C and 140°C.

Below is a summary of this method of producing and laying asphalt with specific reference to modified binders. For more details the reader should consult Sabita Manual 32: *Best practice guideline for warm mix asphalt*.

There are numerous advantages to WMA, some of the important ones being:

- **Environmental Benefits:**
 - Reduced consumption of non-renewable fossil fuels and greenhouse gas emissions;
 - Reuse of by-products which would otherwise require disposal;
 - Increased potential for recycling reclaimed asphalt.
- **Health benefits:**
 - Improved conditions for workers and neighbouring communities.
- **Engineering and economic benefits:**
 - Improved workability which aids compaction and facilitates hand work;
 - Flatter thermal gradings – yielding extended compaction windows and enabling night work and accommodating longer haul distance;
 - Reduced binder ageing.

7.2.2.1 WMA technologies

While a number of technologies that facilitate the manufacture and laying of WMA do not always involve bitumen additives as such, some technologies may alter the consistency or rheological properties of the asphalt binder during the manufacturing/construction process and are listed below for information.

Water technologies

In broad terms, three WMA technologies fall into this category:

- Binder foaming systems where water is injected into the hot binder, causing it to expand significantly into a foam, thereby reducing its viscosity and enhancing its ability to coat aggregate at lower temperatures;
- Water bearing chemical additives or minerals, which introduce moisture into the mix, causing it to vaporize and create foam;
- Systems where moist fines are introduced into the heated coarse aggregate and binder, causing the moisture to vaporize, forming foam.

Chemical additives

These technologies are based on additives that have little effect on the binder's rheological properties and act mainly by reducing the internal friction of the mix, enabling it to be compacted at the lower temperatures. Some additives also improve adhesion of binder to aggregate and resistance to moisture damage.

Rheological modifiers

This broad category includes products that modify the rheological properties of the binder, by reducing its viscosity at mixing and paving temperatures thereby improving aggregate coating and compaction. At in-service road temperatures the binder stiffens, improving resistance to rutting.

Hybrid polymer modification is considered a sub-class of rheology modifier where the principle of co-modification technologies is being used. Such technologies typically employ the combination of an elastomer and a plastomer, sometimes enhanced with the introduction of a chemical crosslinking agent to facilitate a more homogenous modified binder with improved elastic recovery characteristics.

These modifiers differ from the others in this class in that they typically decrease the viscosity of the binder in the liquid state when compared to virgin bitumen. The viscosity of the bitumen, however, is increased upon cooling of the asphalt after construction, resulting in improved asphalt stability and rut resistance.

8. CONSTRUCTION

8.1 Introduction

The use of modified binders in both asphalt and surface seals is currently common practice in South Africa. The fluid characteristics (viscosity) of modified binders are very different from those of conventional bitumen binders. An increase in viscosity and binder cohesion (internal strength) as a result of modification of the bitumen is usually accompanied by a decrease in the initial wetting ability (adhesion) of the binder and therefore a reduction in the initial adhesion of the binder to the aggregate particle. This reduction in initial adhesion can have a significantly detrimental effect on the performance characteristics of both modified asphalt layers and modified seals.

Consequently modified binders require more attention to detail and special considerations of the construction procedures to ensure satisfactory adhesion between the binder and the aggregate in both asphalt and seals.

8.2 Construction procedures

8.2.1 Mixing of polymers

Although blending of the modifier and the base binder is discussed in the respective chapters in this guideline document, it should be noted that blending is sometimes done on site, which might not be under the same controlled conditions as when done in a blending plant. If blending is done on site it is of the utmost importance to ensure that the process is carried out according to the requirements specified by the supplier. Polymers may be supplied in a number of forms including granules or powders. Some polymers can only be satisfactorily mixed in a high-shear mixing plant and cannot be blended on site in a bitumen sprayer or mobile mixing plant.

8.2.2 Storage and handling

Different modifiers have different storage and handling characteristics. The manufacturer should therefore provide information in respect of the type of modifier used, together with the storage and handling characteristics of the product. Recommended handling and storage procedures and temperature to ensure product compliance with the specification should be provided. Some form of mixing and circulation is necessary to maintain homogeneity of all modified binder types while stored. To prevent the development of any "hot spots" within the product or possible segregation, a circulation/stirring system should be in place, even for short periods of storage on site.

8.2.3 Quality control

It is recommended that quality control testing be performed on every batch of modified binder supplied to site. Indicator tests that are quick to perform on site, such as Softening Point and Viscosity, should be carried out on each batch.

8.2.4 Re-constitution

It is generally not possible to reconstitute some of the modified binders if they have lost their required modified properties. A SBS modified binder can, for instance, not be reconstituted while bitumen-rubber and SBR latex modified binders can, in some instances, be reconstituted without any major problems. Reconstituted binders must, however, still meet the specifications that apply to the project.

8.2.5 Contamination

Different classes or types of polymer modified binders must not be mixed, as they may be incompatible and result in a non-useable product or a product with unknown properties. However if a small quantity (< 10%) of polymer modified binder is left in a sprayer or tanker, it may be acceptable to top up the load with conventional bitumen for future works as this will not have any adverse effect on the performance of the bitumen.

Although all the guidelines and best practices applicable to conventional binder asphalt and seals should always be adhered to when modified binders are used, the following aspects should receive special attention.

8.2.6 Surface seal

The following matters should be taken into consideration during the construction of surfacing seals with modified binders:

Weather conditions

Modified binders (even if cut back) should not be sprayed if there is a likelihood of rain or windy conditions. Wind chill causes the rapid formation of a skin on the modified binder, which will delay or even prevent adequate wetting and adhesion to the aggregates. This is especially so for modified emulsions, and spraying should be postponed until conditions are more favourable. Hot modified binders should not be sprayed in the cold months, from May to the end of August unless a special formulation is prepared by the supplier.

The ambient temperature is an important factor when sealing with modified binders. For most modified binder applications, the pavement and air temperatures need to be above 20°C, and higher still where wind chill is expected. Wind chill will cause the binder to 'skin' more quickly and this will delay, or prevent, wetting and adhesion. Warm and dry weather conditions before and after application of the modified binder seal are desirable. Subsequent cold and/or wet weather may result in the aggregate stripping if the adhesive bond is not adequate.

Pre coating

Only pre-coated aggregate should be used with modified binders. The pre-coated aggregate stockpiles should be protected against rain and dust. If heavy rain is experienced on an unprotected pre-coated aggregate stockpile, especially soon after pre-coating, the pre-coating material will wash off.

Only dry pre-coated aggregate (i.e. "hand dry") should be used. A sample should be taken from the pre-coated stockpile and the material should be dry to the touch. Excessively wet pre-coating will influence the bonding time between binder and stone significantly. If the pre-coating practice is inadequate the constructed seal might perform satisfactorily in dry and warm weather, but will lose a considerable portion of the aggregate during the first wet and/or cold weather spell thereafter.

Presence of moisture

The presence of moisture on the surface or within the pavement layer to be sealed should be avoided. The substrate should be totally dry prior to commencement of sealing. Where there is a risk of afternoon showers, consideration should be given to postponing the sealing operations, especially if the road is to be opened to traffic the same day. The glass plate method should be used to determine if any moisture is present in the layer prior to sealing. This method involves a glass plate placed on the layer to be sealed and if no moisture vapour is present on the underside of the glass plate after approximately 15 minutes, the layer can be sealed.

Spray lengths

Due to the decrease in adhesion characteristics of modified binders, it is essential that the aggregate spreading and rolling operations be carried out as soon as possible after application of the binder. Hence, it may be necessary to reduce the length of spray runs substantially from those normally acceptable for conventional binders to ensure that the time delay between binder and aggregate application and rolling is kept to the minimum.

Shady areas

Where sealing is to be done under overhead bridge structures or in localised shady areas, it is considered good practice to commence the spray run at these areas, thereby reducing the time delay of aggregate application and rolling to the minimum. In addition, the binder application rates could be increased by up to 20% in these areas (if approved by the designer).

Production rates

Ideally the pavement and ambient temperatures should be at least 25°C and rising prior to application of the modified binder. It may therefore be prudent to limit the production rates by sealing only in the middle part of the day in order to reduce the risk of aggregate loss.

Spray nozzles

The quality of the spray nozzles is of the utmost importance when spraying modified binders. The required application of binder must be sprayed through suitably sized spray nozzles to ensure that the bitumen binder is spread uniformly on the road surface. The nozzles should be medium size for spraying hot polymer modified binders and large size to spray more viscous modified binders such as bitumen-rubber. All nozzles must be clean, open and function properly, and should be regularly checked for blockages. Hot modified binders are normally sprayed with a uniform triple- or even quadruple overlap.

Binders incorporating a hydrocarbon solvent cutter

Cutting back of modified binders is not general practice in South Africa. The primary purpose of cutting back bituminous binders is to soften the binder temporarily to enable it to achieve adhesion between the binder and the aggregate, and to keep the binder soft enough to allow traffic to fully embed the aggregate into the binder. In most cases conventional cutter oils (e.g. illuminating kerosene or aviation jet fuel) are successfully used, although some polymer modified binders may require a particular type of cutter oil for compatibility. It must be noted that cutting back hot bituminous binders is a hazardous operation.

The cutting back practice of modified binders is based on the same principles that apply to conventional binders, with the amount of cutter oil added related to the class of polymer modified binder, prevailing weather conditions, traffic, aggregate size, and type and condition of pre coating.

It is critically important to assess the applicable pavement surface temperature correctly to determine the appropriate concentration of cutter oil. The quantity of cutter oil added should be based on the likely temperature of the shaded areas on the pavement. The expected prevailing weather conditions for the following few weeks should also be considered. If in doubt, the cutter oil requirement should be based on the worst of the expected conditions. Where a cutter has been added to the modified binder the following should be noted:

- No spraying of cutback modified binder should take place after 14h00, however rolling should continue until later in the afternoon;

- The road should ideally be kept closed to traffic overnight, especially in higher traffic situations, and rolling should continue the next morning;
- The road should only be opened to traffic when the road temperature has risen above 15°C;
- The cutting back of a modified binder will result in a lowering of its viscosity and density, hence the application rate and spraying temperature should be adjusted accordingly.

Contingency plan

Even if all best practice guidelines have been followed with respect to design and construction of the modified binder seal, the unpredictability of weather or other influences, such as plant breakdowns and unforeseen delays, could result in unexpected but significant early aggregate loss. It is therefore considered good practice always to have a contingency plan in place should such situations occur. Such plans should include provision for:

- Emergency closure of the lane at any time (day or night) with appropriate traffic accommodation measures in place;
- Longer term lane closures with additional rolling during the warmer part of the day;
- Application of a fog spray as soon as possible.

Binder-aggregate adhesion

To ensure adequate adhesion a field check should be made by lifting an aggregate particle from the modified binder about one minute after spreading or by dropping it into freshly sprayed binder. The aggregate should retain a coating of binder as it is removed from the sprayed binder. Little or no adhering binder can indicate a need to cease work or to vary procedures (e.g. extended rolling) to ensure adequate adhesion between the binder and the aggregate.

The section of surfacing seal should not be opened to traffic unless there is reasonable confidence that early aggregate loss will not occur.

Adhesion agent

The addition of an adhesion agent to promote bonding of the modified binder with the aggregate particles is common practice. In most instances, double the amount of adhesion agent is used in relation to conventional bitumen. The adhesion agent selected must be compatible with the type of modified binder and the aggregate.

Most commonly used adhesion agents are not heat stable and should not be added to a tanker or other storage tanks long before use. The adhesion agent should ideally be added to the sprayer about half an hour prior to spraying and the binder must be thoroughly circulated.

Repeated dosage of adhesion agents to compensate for loss of effectiveness in storage can have an adverse effect on the adhesion. The stability of adhesion agents is dependent on storage temperature as well as type of adhesion agent, and should be verified by the supplier.

8.2.7 Asphalt

The following matters should be taken into consideration during the construction of asphalt layers with modified binders:

Mixing and compaction temperature

Asphalt mixes incorporating modified binders are generally constructed in a way similar to that of conventional mixes, with the exception that the compaction temperature required can generally be higher depending on the type and percentage of modifier used. The rule of thumb is that the temperature should be increased by 2.5°C for every 1% modifier added to the base binder. This is not applicable to FT wax, EVA and A-R2 (warm mix technology) – see notes below.

It is recommended that information on the temperature-viscosity relationship relevant to the modified bitumen in use be obtained from the binder supplier on a regular basis to ensure that appropriate temperatures are adopted for various operations.

Trial section

A trial section is of utmost importance if modified binder asphalt is to be constructed. At least 100t of asphalt mix should be used in this section to facilitate a thorough investigation of the plant mix properties and all equipment and rolling techniques and patterns.

Haulage

The trucks transporting modified asphalt from the production plant to the site should be insulated and equipped with suitable tarpaulins to ensure a minimum loss in temperature of the mix between the production plant and the site. The haulage limit should be about 4 hours and not more than 2 hours should lapse between arrival of the mix on site and completion of compaction. The use of A-R2 will extend these time limitations; the binder or asphalt supplier should be consulted in this respect.

Weather conditions

Weather conditions play an important role in the time available for compaction of the asphalt mix because of their effect on the rate of cooling of the modified asphalt.

Thick asphalt layers (>40 mm) can be paved at near freezing temperature conditions. Thinner asphalt layers cool more quickly and the minimum air temperature should be about 10°C higher than for thick asphalt layers. Rain and especially wind can have a marked effect on the cooling of asphalt layers. On a windy day it may be found that the modified asphalt layer cools down to below the minimum compaction temperature too quickly to obtain the required density.

Paving of the modified asphalt layer should not continue if rain is likely to occur before compaction of the layer to the required density can be achieved.

Construction requirements

The higher temperature requirement for modified asphalt mixes dictates that particular care must be exercised to ensure that:

- There is adequate compaction plant available to ensure that compaction of the layer is completed within the compaction temperature window;
- Appropriate rolling patterns are determined during the construction of the trial section and employed to expedite the achievement of the required compaction;
- The elapsed time between mixing and placement of the modified asphalt is minimised to avoid excessive cooling of the mix;
- There is a continuous supply of mix to the paver to limit the number of joints as hand work on modified asphalt is difficult. A material transfer vehicle should be given serious consideration when paving modified asphalt;
- The water sprayed on the roller tyres should contain a release agent to prevent pick-up of the compacted mat during the compaction of the asphalt;
- Environmental, health and safety obligations are not compromised.

EVA modified binder

When EVA modified asphalt is used as a binder in asphalt it is important to ensure that the necessary crystalline structure has formed in the binder. This can be observed with the mat moving during the compaction process when the temperature of the mix is too high.

F-T wax modified binder

An exception to the above is when the binder is modified with an F-T wax, which has significantly lower viscosity compared to conventional modified binders at equivalent mixing/compaction temperatures. The appropriate compaction temperatures must be adjusted accordingly otherwise there is a high probability that the paved layer will:

- Exhibit excessive movement under the rollers;
- Develop permanent fine shear cracks allowing ingress of moisture;
- Become over-compacted with associated premature flushing/bleeding of the surface.

A-R2 modified binder

Another exception is when the binder falls within the A-R2 class, which has significantly lower viscosity compared to conventional modified binders at equivalent mixing/compaction temperatures. The appropriate compaction temperatures must be adjusted accordingly otherwise there is a high probability that the paved layer will:

- Exhibit excessive movement under the rollers;
- Become over-compacted with associated premature flushing/bleeding of the surface

Pre coating

Aggregate to be pre-coated for use on asphalt layers should be coated using bitumen that is not softer than 50/70 penetration grade. The reason for this is that a thick film of bitumen is needed on the aggregate to ensure a good adhesion between the pre-coated aggregate and the asphalt mat in which the aggregate has a thin film thickness.

9. QUALITY ASSURANCE DURING STORAGE AND HANDLING

This section deals with the quality related issues arising from the storage and handling of modified binders at a work site, as an integral part of the process flow for handling modified binders shown in Figure 12. For information pertaining to quality management in the loading of modified binders into road tankers, the transport and off-loading thereof, refer to Sabita Manual 25: *Code of Practice: Transportation, off-loading and storage of bitumen and bituminous products*.

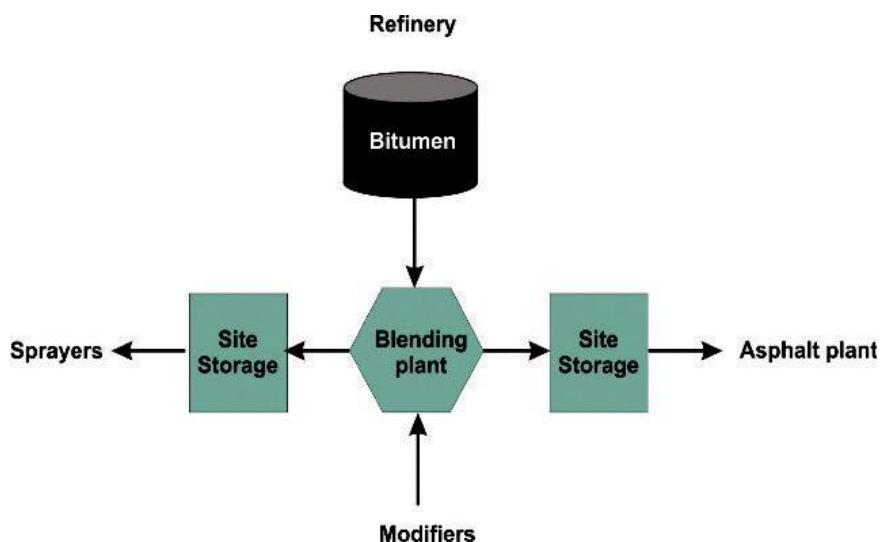

Figure 12: *Process flow for handling modified binders*

9.1 Heating of modified binders

As modified binders are generally applied at higher temperatures, the main difference in the handling of modified binders compared with conventional binders is the need for additional care in ensuring that the effectiveness of the polymer has not been reduced through overheating. Special care must also be taken when heating a modified binder during storage and application to ensure that the properties of the modified binder are not adversely affected.

On-site heating of modified binders is done with flame tubes that protrude into the tank space. Diesel burners are mainly used and these types of burners are also rapidly replacing LPG burners as a means of heating on road and spray tankers. The temperature on the outside of the tube which comes into contact with the binder is in excess of 300°C. By nature, bitumen is a poor conductor of heat and heat transfer takes place through convection when the bitumen is in a fluid state. Therefore, it is imperative that during the heating of a hot-applied modified binder that the following steps are taken to counteract localised overheating of the binder in the vicinity of the flue pipes and possible degradation of the polymer:

- The tank should be designed with a circulation system to ensure that there is a constant movement of binder over the flues during heating;
- It is recommended that tanks which have a volume in excess of 20 m³ be equipped with double flue pipes;
- In the event of having to superheat the binder above 180°C it is essential that tanks are fitted with augers or stirrers to prevent localised overheating;
- The binder should be stored at the minimum pumping temperature, not at the application temperature, and should only be heated to the application temperature just prior to use to limit degradation of the polymer;
- The binder should not be allowed to solidify in the storage tank as reheating will result in localised overheating around the flues. It should rather be heated intermittently over an extended period to maintain a constant storage temperature;
- Rapid heating of the binder should be avoided. As a rule-of-thumb the rate of heating should not exceed 15°C per hour unless the tank is fitted with an agitation mechanism;
- Radiation losses can be minimised by adequate insulation, which will also reduce heating time;
- All tanks are to be fitted with calibrated temperature gauges. In the case of a sprayer a temperature gauge should be fitted on the spray bar as well as the tank to ensure that the binder is sprayed at the correct application temperature;

- All established modified binder storage facilities should strive to install temperature recording devices with automatic temperature controls for heating;
- A method statement on the correct handling and storage temperatures for the modified binder should be obtained from the supplier;
- A distinction should be made between heating of modified binder during transport and static storage;
- Transporters should collect the product at the required temperature and maintain an appropriate temperature during transport;
- Temperature reductions at a rate of approximately 3 – 5°C/hour in hauler tankers, depending on ambient temperature and regaining of the desired storage temperature, should not exceed 15°C/hour.
- Bitumen/polymer deposits will inevitably build up on flame tubes, reducing the heating efficiency and clogging screens and filters. Removal of these deposits should form part of the periodic maintenance programmes. Switching to oil heating should also be considered.
- Methods of heating generally used are:
 - Gas;
 - Diesel;
 - Kerosene;
 - Waste oil;
 - Electricity;
 - Thermal heating – hot oil;
 - Heat exchange – gas/oil;
 - LFO;
 - Coal/steam.

The handling criteria will vary depending on the type of modified binder. This will be discussed in more detail later in this section, but in the absence of any additional information from the supplier, Tables 16, 17 and 18 provide guidelines for the handling of the various classes and types of modified binders.

9.1.1 Hot-applied polymer modified binders

To ensure that the properties of the hot-applied polymer modified binder are not adversely affected during storage, only minimal amounts of heating should be applied to ensure that the product remains pumpable. It is important that hot polymer modified binders are circulated during heating as prolonged, intense heating will cause carbonisation of the binder on the flues and degradation of the polymer. The latter will lead to a reduction in the binder's softening point, resulting in the product not meeting the required specification. Carbonisation on the flues will also reduce the efficiency of the heating system and could lead to blocked nozzles on sprayers. The storage life of the binder at elevated temperatures will vary according to the amount and type of modifier used, compatibility of the base bitumen, and the manufacturing process.

Polymer modified binders should not be kept at their application temperatures for longer than necessary and Table 16 should be used as a guideline. If the heated binder is not used at the end of the work shift, the temperature should be reduced and only super-heated again prior to reuse. Generally the heating of a polymer modified binder above 180°C will result in a reduction of its storage life. If there is any doubt about the suitability of a product after heating and storage, a sample should be taken and the softening point should be checked against the specification.

Table 16 provides a guideline for heating polymer modified binders for normal storage and application purposes. The suppliers of these binders must be consulted to ascertain the appropriate temperatures relevant to their specific type of modified binder. If the recommended time period has been exceeded, samples of the binder should be taken and retested to ensure that the properties of the binder have not degraded.

Table 16: Typical temperature/time limits for polymer modified binders

Binder Class	Short term handling/transport		Storage ¹		Spraying/Asphalt Mixing/Application		
	Max temp (°C)	Max holding time (hrs)	Max temp (°C)	Max holding time ² (hrs)	Max temp (°C)	Min temp (°C)	Max holding time ² (hrs)
S-E1 (SBS, SBR)	180	24	150	240	210	175	8
S-E1 (SBS)	180	24	150	240	185 ³	175	12
S-E2	180	24	150	240	185 ³	175	12
A-E1 (SBR)	180	24	160	240	190	175	8
A-E1 (SBS)	180	24	160	240	180	160	12
A-E2 ⁴	180	24	160	240	180	170	12
A-P1	180	24	150	240	170	150	24
C-E1	160	24	n/a	indefinite	170	150	8

Notes

- ¹ When storing product for 48 – 240 hours it is recommended that the tank has agitation circulation.
- ² If the recommended maximum holding time has been exceeded the binder should be resampled and tested to ensure compliance with the specification.
- ³ S-E1 and S-E2 (SBS) can be sprayed at a maximum temperature of 195°C, but at the risk of thermal degradation.
- ⁴ A-E2 temperatures to be confirmed by practitioners and historical data.
- ⁵ C-E1 Crack sealer is stored cold.

9.1.2 Polymer modified emulsions

Spray grade latex modified bitumen emulsions have to be heated to a temperature of 60 - 80°C, before application. Generally this is done by heating the storage or sprayer tankers by means of flame tube heaters. However it must be noted that the localised over-heating on the flame tubes results in bitumen/polymer deposits being formed on the heating tubes, which can eventually block the spraying nozzles.

To prevent such bitumen/polymer deposits being formed, heating of SBR modified bitumen emulsions should be very gentle, and accompanied by mild pump circulation. Some modern sprayers are equipped with agitators which are very effective in reducing localised over-heating on the burner flues.

No polymer degradation should occur with modified emulsions during the normal temperature range encountered in handling and storage and shown in Table 17. Unlike their hot-applied counterparts, emulsions should not be heated during storage but only prior to application. If polymer modified emulsions are kept in storage for any length of time it is advisable that the binder be agitated gently from time to time.

Polymer modified emulsions are shear sensitive, so pumping must be limited and should preferably be carried out by vane pumps or under compressed air. Where the product is transferred with positive displacement gear pumps, very high shear forces are generated between the gears of the pumps, resulting in shearing of the emulsion. Hence, in such cases, pumping of cold emulsion should be minimised to prevent an increase in the residue on sieving value.

As SBR droplets generally have a lower density than that of penetration grade bitumen, they will have a tendency to migrate to the surface of the emulsion. This is reflected as a white milky layer. The separated latex, can, however, be easily re-dispersed into the emulsion, by simple agitation.

Due to the difference in density between the dispersed bitumen droplets and the continuous phase, there will be a natural tendency for the bitumen droplets to gradually settle at the bottom of the storage tank. Storage tanks containing latex, and modified bitumen emulsions should thus be agitated at least once per week. This can be effected by pump circulation (see below) or by blowing air into the bottom of the tank by means of an air "spider".

The viscosity and residue on sieving results of polymer modified emulsions generally deteriorate fairly rapidly after manufacture of the emulsion. These emulsions should, therefore, be tested within seven days of manufacture to ensure that realistic results are obtained for these parameters.

Polymer modified emulsions should be passed through a strainer when loading and discharging from a tank or sprayer to remove the lumps which form due to skinning. During storage, a skin forms on the surface of the product due to evaporation of the water phase, and pieces of skin may break off over time causing blockages in the nozzles on the sprayers. It is important

that the strainers be checked and cleaned regularly to prevent a build-up of material.

Table 17: Typical temperature/time limits for polymer modified emulsions

Binder Class	Short Term handling/transportation ⁵		Storage		Spraying/Application		
	Max temp (°C)	Max holding time (hrs)	Max temp(°C)	Max holding time ⁴ (hrs)	Max temp(°C)	Min temp(°C)	Max holding time (hrs)
SC-E1/E2 ¹	60	24	Ambient	>240 ³	70	50	6
SC-E1/E2 ²	70	24	Ambient	>240 ³	80	50	6
CC-E1	Ambient	240+	Ambient	>240 ³	Ambient		240+

Notes

- ¹ This applies to modified emulsions with a binder content of approximately 65% m/m.
- ² This applies to modified emulsions with a binder content of approximately 70% m/m.
- ³ The modified emulsion should be gently circulated or stirred at regular intervals to avoid sedimentation over time.
- ⁴ If the recommended maximum holding time has been exceeded, the binder should be resampled and tested to ensure compliance to the specification.
- ⁵ Freshly manufactured product that is transported direct to site may exceed short term handling and transportation maximum temperatures.

9.1.3 Bitumen rubber

Bitumen-rubber degrades rapidly at application temperatures in excess of 200°C. Therefore the blending of bitumen rubber generally takes place in close proximity of the spray site or asphalt mixing plant. On completion of the digestion period, the product generally has a further useable life at the application temperature of approximately 6 – 8 hours. The rate of degradation will vary depending mainly on the application temperature and can be monitored on-site with a hand held viscometer. The manufacturer of the bitumen rubber should supply temperature curves showing the changes in the properties over time. Figure 13 shows typical changes in the viscosity properties of a bitumen rubber at different temperatures over time.

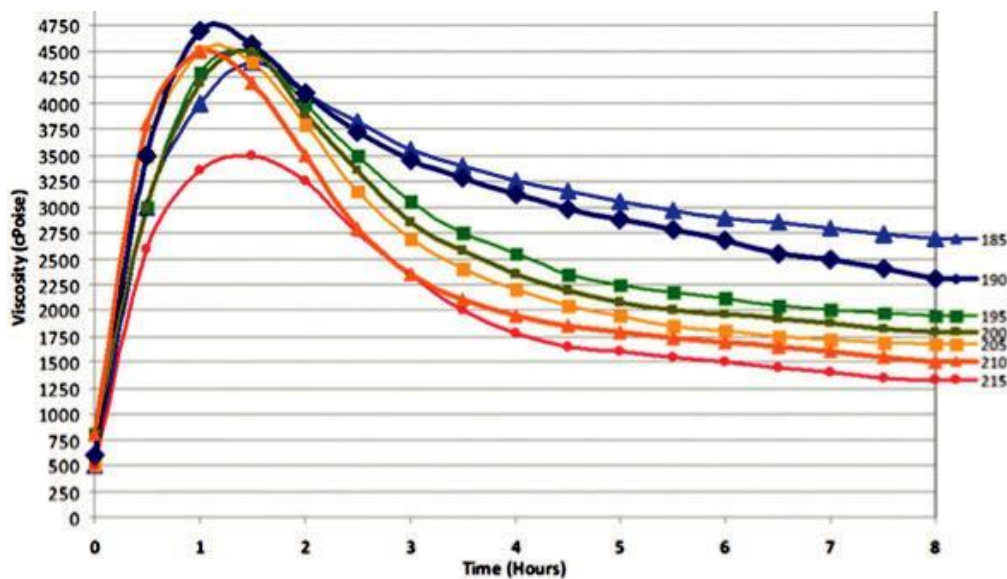

Figure 13: Typical changes in viscosity values for bitumen rubber at different temperatures over time

A dual set of heating flues is required in the storage and spray tanks to heat the bitumen-rubber to the required elevated temperature. An auger or stirring mechanism must also be installed in the vicinity of the heating flues to prevent localised

overheating and carbonisation of the binder. A positive displacement gear pump capable of pumping a liquid with a viscosity of up to 5000 cP is required to transfer and spray the bitumen rubber binder. Only sufficient quantities of bitumen rubber should be blended at any time in accordance with what can be sprayed or mixed within the application viscosity window of the product. Allowance must be made for changing weather conditions and construction delays.

Proper planning and close cooperation between the supplier and contractor is essential to limit the over-production of bitumen-rubber, which may result in unnecessary degradation of the binder over prolonged periods of heating. The product must not be super-heated if it is not going to be used. This will enable the product to be reheated at a later stage for reuse if it is still within specification. If it is out of specification, up to 25% can be blended with new bitumen and rubber crumbs for spray application. In asphalt applications the use of higher proportions of degraded binder can be considered, but will in all likelihood require additional rubber crumb to meet the specification requirements. The reader is referred to Sabita Manual 19: *Guidelines for the design, manufacture and construction of bitumen-rubber asphalt wearing courses*.

Table 18 shows the recommended temperatures and time limits for the short-term handling, storing, spraying, mixing and application binders modified with bitumen rubber.

Table 18: Typical temperature/time limits for bitumen rubber

Binder Class	Short term handling		Storage		Application/asphalt binder feed		
	Max Temp (°C)	Max holding time	Max temp (°C)	Max holding time (days)	Max temp (°C)	Min temp (°C)	Max holding time (hrs)
S R1	170	24 hours	150	10 ¹	210	195	Refer to time/viscosity curve
S-R2	160	> 7days ¹	150	>14 ¹	190	180	
A R1	170	24 hours	150	10 ¹	210	190 ²	
A-R2	160	> 7days ¹	150	>14 ¹	185	170	
C-R1	165	24 hours	-	-	190	180	
C-R2	160	> 7 days ¹	150	>14 ¹	185	170	

Notes

¹ If the recommended time period has been exceeded the binder should be resampled and tested to ensure that the properties of the binder have not degraded.

² Minimum temperatures for asphalt manufacturing are viscosity-dependent.

9.2 Contamination

Contamination of modified binders with other bituminous binders or petroleum products can adversely affect their performance properties. The largest risk of contamination occurs during the transporting and storage of the product. Prior to loading by a haulier, or transferring product into site storage tanks or a sprayer, it is essential that the tank be clean, and that it contains no other product, unless it is a dedicated tank. In that case it is essential to ensure that the product in the tank still complies with the relevant specification. Some modified binders (e.g. bitumen-rubber and hot modified SBR binders) have limited storage lives and are more prone to degradation during prolonged heating. Should this material be mixed with new product, the final product could be out of specification.

When changing products, proper flushing procedures must be followed to avoid any possibility of contamination between incompatible products that could adversely affect the product quality or possibly result in a boil-over in the case of an emulsion. More details are provided in section 3.8 in Sabita Manual 25: *Code of Practice: Transportation, off-loading and storage of bitumen and bituminous products* related to the changing of product and flushing procedures.

9.3 Quality assurance

Due to the specialist nature and time required to complete some of the prescribed tests, it is not feasible to conduct the full spectrum of tests at the point of manufacture prior to dispatch, or on-site prior to application of the binder. The main objective of the quality assurance process is to ensure that product supplied meets the required specification, and that the quality of the binder is maintained until it is applied. From the time the product is dispatched from the blending plant it is exposed to the risk of contamination and degradation, unless the binder is handled in the correct way. This could occur mainly through overheating and shearing at the different stages of handling from loading, transporting, offloading and storage, until it is mixed with aggregate or sprayed.

To ensure that the properties of the applied modified binder have not changed significantly from that of the original product dispatched from the blending plant, the following quality control measures are recommended:

- The supplier must conduct the necessary tests on the product to ensure that it meets the specification requirements before dispatching the product. The supplier must keep retention samples for each batch for a period of 12 months following the completion of the project. In the case of modified emulsions this period can be reduced to 3 months from date of manufacture;
- The supplier should supply a laboratory certificate for each batch stating the binder properties. This might not include all the test requirements but should contain the indicative tests like softening point. The batch certificate should be transmitted to the site electronically or delivered by the haulier driver;
- Samples should be taken from the haulier while the product is being discharged on-site, and these should be retained for further testing in the case of a dispute. This is the responsibility of the receiving party;
- Samples should be taken from the site storage tank on a daily basis and tested prior to application. In the case of a sprayer, samples should be taken for every load sprayed;
- Product not applied can be returned to storage and retested for compliance prior to further use;
- All samples must be clearly labelled on the side of the container and NOT on the lid, with all relevant details for ease of identification and traceability;
- To limit the potential for a dispute arising from test results of the manufacturer and the site laboratory, it is recommended that correlation testing be carried out between the laboratories prior to the supply of binder to identify any discrepancies.

On commencement of a contract, the full spectrum of tests should be conducted on the first batch of the product manufactured or delivered on site, to demonstrate the supplier's ability to comply with the specification. Thereafter, the respective tests should be conducted at an agreed frequency unless there is a change in the source of raw material (base bitumen or polymer).

In the case of bitumen-rubber, the supplier must also provide a set of curves showing the changes in the flow, softening point and viscosity with time at various temperatures relevant to the technology stated in the company's method statement.

Tables 19, 20 and 21 provide an indication of the frequency level for all the tests required at the different stages.

Table 19: Test frequencies for hot polymer modified binders

Property	Manufacturer	Haulier	Site storage	Sprayer
Before ageing				
Softening point	Every batch	Every load	Every day	Every load
Elastic recovery @ 15°C	Every batch			Every 5th load
Dynamic viscosity @ 165°C	Every batch			Every 5th load
Storage stability @ 180°C ¹	Every 10th batch			
Flash Point	Once, at start of project			
After ageing (RTFOT)				

Mass change	Every 10th batch			Every 10 th load
Difference in Softening Point	Every 10th batch			Every 10 th load
Elastic recovery @ 15°C	Every 10th batch			Every 10 th load

Note

¹ This test should be performed on a frequency basis or whenever there is a change in the source of base bitumen or bitumen crude type.

Table 20: Test frequencies for polymer modified emulsions

Property	Manufacturer	Haulier	Site storage	Sprayer
Binder content (m/m)	Every batch	Sample only	Every day	Every load
Saybolt Furol viscosity @ 50°C	Every batch			
Residue on sieving (/100 ml)	Every batch			
Particle charge	Every 5th batch			
Sedimentation after 60 rotations	Every 5th batch			
Recovered binder residue				
Softening point	Every batch			Every load
Elastic recovery @ 15°C	Every batch			

Table 21: Testing frequency for bitumen rubber

Property	Spray tanker	Asphalt storage tank
Softening point	Every load	Every batch
Dynamic viscosity ¹	At the start of every load	At the start of every batch
Compression recovery: 5 minutes 1 hour	Every 5th load	Every 5th batch
Resilience	Every 5th load	Every 5th batch
Flow	Every load	Every batch

Notes:

¹ Dynamic viscosity is an indicator of the product quality. Attempts should be made for viscosity to be measured at the specified temperature (see Table 8).

If the viscosity is not measured at the appropriate temperature on site, its value at the appropriate temperature can be determined using the relevant temperature-viscosity relationship.

For S-R2 and A-R2, where viscosity is specified at 170°C, products can be certified at the blending source in respect of both softening point and viscosity due to their stability.

9.4 Site quality control plan

Prior to the commencement of a contract during which a substantial volume of modified binders is to be applied, it is recommended that a pre-supply meeting be convened between the modified binder supplier, the contractor and the engineer. The following issues should be resolved:

- Quality control issues including:
 - Binder test requirements and testing frequencies;
 - Sampling plan and who is responsible for taking of samples;
 - Responsibility for the provision of laboratory certificates for the base bitumen and the modified binder;
 - Supplier's method statement regarding the handling and storage temperatures, and time constraints for the various binders.
- The contractor's production programme and the binder quantities required on a daily basis including:
 - Procedures for ordering product including minimum lead times;
 - On-site binder storage requirements to meet the demand, including heating and pumping requirements;
 - Protocol for re-constituting off-specification product.
- Environment management plan for storage, spillage control and waste disposal of binders and flushing.

The above items should be recorded in writing and form part of the quality management plan for compliance by all parties.

10. SAMPLING AND TESTING

The sampling and testing of modified binders is more susceptible to complications than conventional binders, due to the fact that they are multiphase systems which are very sensitive to heat and shearing. Hence the thermo-mechanical history of a modified binder could have a major influence on its properties. As a result, these products must be handled in a standard way during the taking and the preparation of samples prior to testing. If these procedures are not followed, the test results could vary substantially beyond the normal precision limits.

10.1 Sampling

All modified binders should be sampled in accordance with the procedures provided in Method MB-1: *Sampling of modified binders*. MB-1 covers sampling from bulk storage, during loading, and from sprayers and drums. It is also important that the samples are representative of the batch being tested. Hence, it is imperative that the binder be thoroughly mixed in the tank before sampling to ensure that the binder is homogenous.

10.1.1 Safety precautions

Strict precautions must be adhered to when taking samples of hot modified binders to avoid injury. The procedures set out in Sabita manual 25: *Code of Practice: Transportation, off-loading and storage of bitumen and bituminous products* must be adhered to.

All storage tanks and spray tankers should be fitted with sampling valves and the use of a thief sampling device should be avoided. If the spray-bar has nozzles which can be opened individually, a sample may be taken from a spray nozzle. At no stage may an open tin can be used to take a sample from the top of a tank. The sampling valve should be located on a circulation line with a permanent support on which to rest the container during filling. Road tankers (haulers) should not be fitted with sampling valves as they have no means of circulating the product. Therefore, samples must be taken in-line at the binder plant when loading, or when the product is offloaded at the site storage tank.

Appropriate sample containers must be used which are new, clean and can be properly sealed. See 10.1.2 below. All sampling should be carried out by properly trained personnel. It should be noted that a correct sampling procedure is an essential prerequisite for obtaining accurate and precise test results.

10.1.2 Sampling containers

Containers for liquid bituminous materials, except emulsions, should be wide-mouth cans with lined screw caps of triple friction-top cans.

Containers for emulsified bituminous materials should be wide-mouth plastic-lined cans with lined screw caps of plastic-lined triple-seal friction-top cans.

Containers for crushed or powdered bituminous materials should be triple-seal friction-top cans or plastic sacks placed in other containers suitable for handling.

The size of the container should correspond to the required amount of sample.

10.1.3 Monitoring of product during handling

As part of every project, sampling and testing procedures should be established to monitor the properties of the binder from the point of manufacture to the point of application. Table 22 shows the recommended sampling points in the supply chain:

Sample point	Responsibility
1 From the finished product storage tank prior to releasing the product	Supplier
2 In-line during discharge from the finished product storage tank and the loading of the road tanker	Supplier
3 In-line during off-loading from the road tanker into the on-site storage tank or sprayer	Asphalt manufacturer/ applicator
4 From the on-site storage tank prior to mixing in an asphalt plant or from the sprayer's sampling valve prior to spraying	Site engineer

The manufacturer must take a sample from the finished product tank (1) and test the product against the specification requirements prior to releasing the product. The reason for taking subsequent samples at the various points in the supply chain (2, 3 and 4) is for quality assurance purposes. It is important to ensure that the quantity of the sample is sufficient to conduct the necessary tests. The samples taken prior to sampling point (4) should be split into three containers for reference purposes in the case of a dispute in the test results or for further testing. These samples must be properly labelled with all the relevant information pertaining to the sample taken to provide for adequate traceability in the event of a dispute. The testing frequency must be agreed in the quality management plan. In the absence of such a plan, Tables 19, 20 and 21 in Chapter 9 can be used as guidelines.

10.1.4 Storage of samples

The above samples are not necessarily tested but retained for the duration of the contract's defects liability period, which is normally 12 months after completion of the contract. To ensure that the properties of the sample taken do not change during storage, the samples must be stored:

- In airtight containers;
- At an ambient temperature of $25^{\circ}\text{C} \pm 5^{\circ}\text{C}$.

Storing the samples in metal shipping containers or outdoors in direct sunlight should be avoided. Any deviation from the above can affect the properties of the sample. In the case of a modified emulsion, the quality of the emulsion will start deteriorating after 3 months, thus limiting the duration to a maximum period of 6 months before sedimentation takes place.

10.1.5 Sample preparation

Since modified binders are heat-sensitive, these binders can undergo significant changes in their properties if exposed to high temperatures for extended periods. Such changes could be degradation and/or separation of the polymer from the base bitumen. Hence, improper heating of the samples can lead to non-representative test results of the modified binder actually supplied. To avoid a disparity in test results it is important that the modified binder samples undergo a minimum and controlled amount of heating. Method MB-2: *Sample preparation* details the procedure for preparing polymer modified binders and bitumen rubber prior to testing.

A convection oven must be used to reheat samples from room temperature until the binder is liquid enough to handle. The use of a hot plate for this purpose is not acceptable as the source of heat cannot be accurately controlled and measured, and will increase the risk of localised over-heating. Once the sample is liquid, a low-shear mechanical stirrer with variable speed should be used to ensure a homogeneous sample which is representative of the original binder.

To ensure that the test results are repeatable and reproducible between laboratories, the supplier and engineer should agree on a procedure for reheating samples in the site laboratory. This should include standardisation in terms of method MB-2 on:

- Type of equipment used to heat the sample;
- Rate and period of heating;

- Type of stirring mechanism to be used.

10.2 Testing of modified binders

The samples should be tested for compliance with requirements in accordance with the methods given in Appendix 1 of this manual. The intention in the longer term is that these methods will be incorporated as SANS standards and will not form part of this guideline in the future. At the time of publishing, discussions were underway with SABS to embark on this process and the reader is urged to monitor these developments.

It is important that split samples of the modified binder are sent to all the participating laboratories (e.g. supplier, site and control laboratories) and tested before commencement of a project to ensure that the results are within the reproducible limits as prescribed by the test methods.

10.3 Asphalt mix design

The properties of the modified binder will influence the engineering properties and performance characteristics of the asphalt mix. The substitution of a modified binder for conventional bitumen in an asphalt mix can result in higher air voids due to reduced workability associated with the higher viscosity of modified binders. The traditional method of determining the binder's optimum mixing and compaction temperatures, based on given viscosities of 170 and 280 Pa.s respectively, is not applicable to modified binders, and unrealistically high temperatures are obtained when determining equivalent mixing and compaction temperatures for polymer modified binders using this approach. This is due to the phenomenon of 'shear thinning' arising from the non-Newtonian behaviour of these binders.

The recommended approach is to conduct the asphalt mix design using conventional bitumen to determine the volumetric properties of the mix. Once the design target values have been achieved, it is recommended that the conventional bitumen be substituted with the modified binder, that briquettes be compacted at different temperatures, and that the resultant air voids of the mix be measured. The temperature which equates to the design air voids is then used as the compaction temperature.

The changes in the theoretical mix relative densities must also be taken into account. The mixing temperature of the modified asphalt should be approximately 15 to 20°C higher than that of conventional bitumen. As a rule of thumb, in cases where SBS modification is used, the compaction temperature should be increased by 2 to 3°C per % of SBS modifier used.

However, the supplier of the modified binder should be consulted to provide guidelines on mixing and compaction temperatures for this purpose. For the design of asphalt with bitumen-rubber, the reader is referred to Sabita Manual 19: *Guidelines for the design, manufacture and construction of bitumen rubber asphalt wearing courses*.

11. PROTOCOL FOR INTRODUCING A NEW MODIFIED BINDER PRODUCT

The intention of TG1 is that the recommended limits for modified binders generally remain polymer blind and based on end property parameters. Therefore, the onus rests on the supplier to source the appropriate type and quantity of polymer to modify the base bitumen such that the end property requirements, in line with the specification, are met.

To date the most commonly utilised modifiers have been SBR, SBS, crumb rubber and, to a lesser degree, EVA. A performance history of these modifiers has been accumulated over the last number of decades and correlated with the regimen of tests prescribed in this document leading to the limits specified for the purpose of controlling quality, and consistency of manufacture. Due to the current lack of true performance-based properties and specifications, the recommendations do not necessarily guarantee the binder's fitness-for-purpose for all the various applications and environmental conditions likely to be encountered during its service life.

A modified binder is but one component material within a layer system, and factors such as, *inter alia*; aggregate properties/ packing, construction techniques, traffic, temperature as well as mix/seal design methodology will have an influence on the long term performance of such a system. The purpose of this section is to develop a protocol for introducing new modified binders in order to encourage innovation in a controlled and responsible manner. This is best achieved through a combination of conducting laboratory tests on the binder (with and without aggregates) and evaluating the binder's performance during field trials.

11.1 Laboratory testing

Prior to a new modified binder being used in the field it is recommended that the following laboratory tests, where appropriate, be conducted:

- A full set of tests as specified in accordance with TG1;
- In the case of the binder being used in asphalt, the following comparative tests should be considered to obtain an indication of the binder's relative contribution to the desired performance properties of the mix, *vis-a-vis* that of a known binder using a standard mix¹;
 - Workability – Air voids after a number of gyratory compactor cycles (ASTM D 6925);
 - Durability/TSR – Modified Lottman test (ASTM D 4867 M);
 - Stiffness – Indirect tensile strength (ASTM D 6931) or AMPT stiffness/dynamic modulus (AASHTO TP 79);
 - Resistance to permanent deformation – Creep modulus (Dynamic creep test, CSIR RMT 004) or determining the Flow Number using the Asphalt Mixture Performance Tester (AMPT) as described in AASHTO TP 79;
 - Fatigue resistance – Semi-circular bending test, SCB, (BS EN 12697-44) or the four point beam fatigue test (AASHTO T 321);
 - Viscosity parameters to determine appropriate mixing and compaction temperatures;
 - Short term binder ageing - RTFOT;
 - Compatibility with available base bitumens - Storage stability (changes in properties over time);
 - Special tests – Fuel resistance, drain down test.
- In the case of the binder being used in a surfacing seal the following tests should be performed, if relevant, against conventional bitumen and known modified binders:
 - Elasticity @ 15°C – Elastic recovery;
 - UV resistance/ageing;
 - Viscosity parameters to determine spray temperature;
 - Compatibility with available base bitumens - Storage stability (changes in properties over time).

Comparative adhesion tests may also be conducted, while bearing in mind that adhesion of the binder to the aggregate is largely influenced by construction practice. Tests such as the Vialit adhesion test, can be selected for this purpose, subject to agreement of the parties involved.

¹ The specific test adopted for a particular performance characteristic would depend on the level of sophistication adopted in relation to the class of road and prevailing traffic and environmental conditions.

11.2 Field trials

Field trials should be conducted to evaluate the performance of the new modified binder under varying traffic and climatic conditions over time. The construction of the trial section should allow for the substitution of a known binder in the surfacing seal or asphalt with the new binder in such a way that the new binder is subjected to the same service conditions as the "control" section. It should however always be borne in mind that it is not always possible to simply substitute one particular binder with another (mass/mass or volume/volume) as particular properties could dictate that some adjustments be made to the specific seal or mix design. If at all possible, from a perspective of the associated risk of poor performance, it is always desirable to construct the trial at varying binder content/application rates to fully assess the sensitivity of the product to variations in design. For the construction of asphalt trial sections, a minimum quantity of 100 tons of asphalt is required to achieve a representative mix. The start and end points of the trial sections are to be recorded and marked on site for future assessments. During the construction of the trial section the following aspects need to be recorded:

- General:
 - Section identification;
 - Date and time of construction;
 - Weather conditions;
 - Air and pavement temperatures;
 - Substrate condition;
 - Vertical and horizontal alignment of pavement;
 - Drainage conditions;
 - Traffic conditions;
- Material and construction details:
 - Component material properties;
 - Asphalt mix properties;
 - Modified binder application temperatures;
 - Application rates;
 - Type and number of roller passes.
- Post construction assessment:

On completion and at agreed intervals, ideally every 6 months before and after winter, and/or the rainy season, a visual inspection should be carried out of the trial sections along with an appropriate testing protocol. The visual inspection should evaluate, where appropriate, the following functional properties:

 - Surfacing texture;
 - Aggregate loss;
 - Binder appearance and condition;
 - Crack extent and activity;
 - Any signs of surfacing distress.

The following measurements and tests should be conducted:

- Rut measurements in wheel tracks;
- Surface texture;
- Skid resistance;
- *In situ* performance based tests e.g. MMLS (wet or dry).
- Cores or slabs should be taken to determine:
 - Binder properties;
 - Asphalt mix volumetrics and engineering properties.

The trial sections should be monitored over a period of time to allow for a proper evaluation. However, experience has shown that if problems are likely to be encountered with the performance of a newly launched binder, they will generally become manifest, or give an indication of potential problems, after the first summer and winter cycle.

If justifiable, use should be made of accelerated pavement testing (APT) on the test sections to assess long term performance of the candidate materials.

It is always desirable to have any performance assessments of "new product" trial sections carried out by knowledgeable and independent practitioners. Information gained from the laboratory tests and field trials must be recorded and made available to road authorities/specifiers, so that they will be in a position to make meaningful assessments as to the suitability of the new binder for the required application.

APPENDIX 1 – TEST STANDARDS

Note:

All test standards listed refer to the current version of the standard. Where the test standard refers to other standards or methods, these are not listed – they are deemed to be an integral feature of the standard.

METHOD MB-1: SAMPLING OF MODIFIED BINDERS

1. Scope

This test method sets out the procedures for the sampling of polymer modified binders and rubber bitumen blends.

Definition

The object of sampling to prescribed protocols is to ensure that correct sampling procedures are followed and that results provide the required information on a composite sample that is representative of the whole.

2. Apparatus

- 2.1 One-litre open top metal tins fitted with a triple-seal-friction lid for the storing of binders;
- 2.2 A sampling thief;
- 2.3 A thermometer measuring 0 - 200°C in increments of 1,0°C;
- 2.4 Heat resistant gloves for handling of hot equipment;
- 2.5 Safety glasses or face shields for protection while sampling.

3. Method

3.1 Sampling from bulk storage

Samples should be taken from a bulk tank by means of a sampling "thief" or via a sampling valve. The sample valve may be attached to the side of the tank or built into the discharge line. The sample should be drawn when at least one third and not more than two thirds of the contents of the tank have been discharged.

- 3.1.1 The contents of the bulk tank should be thoroughly mixed by pump circulation or stirring for at least 30 minutes. In the case of A-R1 and A-R2 the time of circulation should allow for a volume of at least 1.5 times that of the container to be circulated;
- 3.1.2 After ensuring proper circulation through the line on which the sampling valve is located, withdraw approximately 4 litres and discard by returning to the bulk product. Draw four one-litre samples for testing purposes. Seal containers immediately after sampling.

3.2 Sampling from sprayers

- 3.2.1 Circulate the contents of the sprayer at least 15 minutes before sampling. If the sprayer is fitted with an agitating mechanism such as an auger, the sample can be taken sooner;
- 3.2.2 The sample can be taken from the spray bar after ensuring proper circulation through it, a sampling valve

3.3 Sampling from drums

- 3.3.1 Select the number of drums at random. Sample one drum from each batch and test against specification. If the sample does not comply with the specification, then several containers must be sampled. As a guide, the number should be the cubed root of the total number of drums in the batch;
- 3.3.2 Mix the contents of the drums to be sampled thoroughly by rolling, turning end over end and stirring if necessary;
- 3.3.3 If emulsion is being sampled, place a suitable rod through the bung and establish whether excessive sediment and/or separation are present at the bottom of the drum. As the rod is withdrawn, examine closely for signs of lumps or extraneous matter;
- 3.3.4 Pour four one-litre samples for testing purposes. Seal containers immediately after sampling.

3.4 Labelling

Ensure that samples are securely packed for transport to the testing laboratory. The sample must be clearly identified by marking on the lid and the container. The following information should appear on the label:

- Client;
- Project number;
- Type of material;
- Batch number;
- Date and time;

- Sampling temperature.

3.4 Storing of samples

Store the samples in a cool place (below 30°C) until they are tested. Bitumen emulsion samples should be tested not later than 10 days after sampling.

4. Notes

4.1 Safety Precautions

Strict precautions must be taken at all times to avoid injury or the risk of fire, when handling hot polymer modified binders. The following are some of the precautions to be taken in the handling of these binders:

- 4.1.1 Safety glasses or face shields must be worn whilst sampling;
- 4.1.2 Heat resistant gloves, with close fitting cuffs and other suitable protective clothing should be worn during sampling;
- 4.1.3 Sample containers should be held with tongs or supported on a suitable tray while the sample is being taken;
- 4.1.4 Smoking should not be allowed during sampling;
- 4.1.5 Sampling personnel should stand away from the sampling valve and on the windward side;
- 4.1.6 The sample valve should be opened very slowly to prevent a sudden outflow of hot material;
- 4.1.7 See also Sabita Manual 8: *Guidelines for the safe and responsible handling of bituminous products.*

4.2 Sampling precautions

Samples shall be taken in clean one-litre containers free from any contamination by solvents and other bituminous binders;

Seal the sample tightly immediately after sampling. Wipe any spilled material on the outside of the tin with a clean dry cloth immediately after sampling. Do not use solvent soaked cloths.

Reference:

Austrroads Modified Binder Test MBT 01.200.

METHOD MB-2: SAMPLE PREPARATION

1. Scope

This method describes how samples of homogeneous polymer modified bitumen and non-homogeneous bitumen-rubber are prepared prior to testing.

2. Apparatus

- 2.1 An oven capable of temperatures of 200°C for heating bituminous materials with an accuracy of $\pm 5^\circ\text{C}$;
- 2.2 Spatula suitable for stirring the samples;
- 2.3 Thermometer to read up to 200°C in increments of 1°C.
- 2.4 Controllable hot plates or Bunsen burner.

3. Method

Sample reduction from bulk (samples larger than 2 litres). This method is not applicable to modified bitumen emulsions. The procedure shall be as follows:

- i. Heat the bulk sample to the required temperature, allowing sufficient time to reach this temperature;
- ii. Remove the sample from the oven and thoroughly stir it for 30 seconds with a spatula without entraining air;
- iii. Divide the bulk sample into sub-samples using smaller containers of 1 litre capacity.

3.1 Bitumen emulsion

Open the sample container and examine the sample for signs of settlement. Stir the sample until homogeneous before testing. If unable to reconstitute the sample due to irreversible settlement, mark the sample "Unable to test due to settlement".

3.2 Bitumen-rubber

- 3.2.1 It is assumed that the samples are cold when received;
- 3.2.2 A-R2 and S-R2 can be tested hot, if sampled direct from the production line.
- 3.2.3 Two one litre samples are required. One sample for the viscosity test and the second sample for the remainder of the tests;
- 3.2.4 Open the sample containers. If unable to remove the lids, make a small hole in the lids to allow for air to escape.
- 3.2.5 Place the samples in an oven maintained at 180°C;
- 3.2.6 After two hours in the oven, the samples should be sufficiently fluid. Do not keep in the oven for longer than 3 hours;
- 3.2.7 Remove the sample required for the viscosity test from the oven. Heat to the final test temperature of 180°C over a suitable heat source, while stirring continuously with a spatula, before performing the viscosity test;
- 3.2.8 Homogenise the second sample by stirring for approximately 5 minutes with a spatula after removal from the oven. Gentle heating over a controllable heat source will be required to maintain the temperature at approximately 160–170°C;
- 3.2.9 Immediately pour into the test moulds.



Note:

If hot sub-samples were received, proceed from 3.2.6 above.

3.3 Polymer modified binders of the type A-P1, A-H1 & A-H2

It is assumed that the sample is cold when received.

- 3.3.1 Open the sample container. If unable to remove the lid, make a small hole in the lid to allow for air to escape. Place the sample in an oven maintained at a temperature of $180 \pm 5^{\circ}\text{C}$;
- 3.3.2 After two hours the samples should be sufficiently fluid. Do not keep in the oven for longer than 3 hours;
- 3.3.3 Homogenise the sample by stirring for approximately 5 minutes with a spatula while heating over a controllable heat source. Do not heat to a temperature higher than 180°C ;
- 3.3.4 Immediately pour into the test moulds.



Note:

If hot sub-samples were received, proceed from 3.3.3 above.

3.4 Polymer modified binders of the type S-E1, A-E1, S-E2 and A-E2

- 3.4.1 It is assumed that the sample is cold when received.
- 3.4.2 Open the sample container. If unable to remove the lid, make a small hole in the lid to allow for air to escape;
- 3.4.3 Place the sample in an oven maintained at a temperature of $180 \pm 5^{\circ}\text{C}$;
- 3.4.4 After two hours the sample should be sufficiently fluid to pour. Do not keep in the oven for longer than 3 hours;
- 3.4.5 Homogenise the sample by stirring for 30 minutes with a variable speed electric stirrer fitted with a paddle mixer, while controlling the temperature at 170 to 180°C . The speed of the stirrer should be carefully controlled to minimise the risk of entraining air into the sample;
- 3.4.6 Immediately pour into the test moulds.



Note:

If hot sub-samples were received, proceed from 3.4.5 above.

4. General

- 4.1 Polymer modified binders are complex mixtures of polymers, bitumen and other petroleum additives. Due to the higher than normal handling temperatures, the risk of burning with polymer-modified bitumen is higher than with standard bitumen. Notices describing the action to be taken in case of burns should be prominently displayed in the laboratory. The safety precautions mentioned under Method MB-1: *Sampling polymer modified binders* should be taken;
- 4.2 As the properties of polymer modified binders are affected by the handling of the sample in the preparation of test specimens, it is necessary to strictly adhere to the preparation procedures described above;
- 4.3 Polymer modified bitumen is characterised by the formation of a structure on cooling after blending of the constituents. The sample must thus be heated to a temperature at which this structure will be broken down before testing and moulding test specimens. The rate of cooling influences the structure formation and, therefore, conditions under which specimens are cooled prior to testing must be controlled;
- 4.4 Polymer modified binders are heat sensitive materials and may undergo significant changes in their properties if exposed to high temperatures for extended periods. Improper heating can therefore, result in sample test results that may not truly represent the characteristics of the material.

METHOD MB-3: MODIFIED ROLLING THIN FILM OVEN TEST

1. Scope

This test method sets out the procedure to measure the effect of heat and air on a moving film of semi-solid polymer modified bitumen material. To address the complex flow characteristics that occur in the RTFO bottles, an alternative test method has been developed to reduce this problem. This method has a larger quantity of binder and a metal treatment bottle with an internal roller to assist the flow of the binder through treatment.

Definition

The test simulates the effect of the manufacturing process where bitumen is hot mixed with aggregate for asphalt production. The oxidation effects at mixing temperatures (typically in the range of 150°C to 170°C) on the thin binder films that occur during asphalt manufacture, transportation and placement are simulated by the RTFO test conducted at an oven temperature of 163°C over a period of 90 minutes. This test therefore indicates approximate change in the properties of bitumen, which is indicated by viscosity measurements, softening point, penetration and elastic recovery testing undertaken on the binder residue that remains after the RTFO test is completed.

The test is also used to determine the mass change after RTFOT.

2. Apparatus

The following apparatus is required in addition to that listed in ASTM: D2872 (see note 5.1)

- 2.1 A suitable balance of 1 kg capacity to 0,001g;
- 2.2 Metal treatment bottles and rollers in accordance with the description in Figure 1.

3. Method

3.1 Sample preparation

Polymer modified bitumen samples for testing shall be prepared in accordance with method MB-1 and method MB-2.

Heat the sample in its container with a loosely fitted cover in an oven not exceeding the treatment temperature for the minimum time necessary to ensure that the sample is completely fluid. Manually stir the sample but avoid incorporating air bubbles. Select the required number of sample bottles to produce sufficient material for characterising tests, which are to be performed on the residue. Allow the treatment bottles (with rollers) to cool to approximately room temperature (18 – 25°C). Add 40g of sample to each bottle.

3.2 Sample Treatment

With the oven at the treatment temperature for at least 2 hours, insert the treatment bottles and rollers into the carriage in a balanced arrangement and fill any remaining spaces with empty bottles.

Leave the samples for 30 minutes without rotating the carriage or any air flowing.

Start the rotation of the carriage and the air flow with the flow meter indicating 4 ± 0.5 l/min.

Maintain the samples in the oven for 60 min ($\pm 10s$), and then switch off the carriage and airflow.

3.3 Treatment sample

Leave the samples to settle in the oven for 1 – 2 minutes. To aid sample collection, the lid can be removed and the roller suspended above the treated material.

Taking out one bottle at a time, pour the contents from each bottle into a suitable container for testing. Drain each bottle until the treated material stops running freely (just dripping).

Stir the material in the container briefly to ensure that the contents from all bottles are mixed to yield a representative sample.

Testing on the treated samples should be completed within 24 hours.

4. Report

Comment on the sample behaviour during the test, in terms of its flow characteristics.

If sample flow is restricted at any stage during the test, oxidation of the binder, or loss of volatiles will be reduced and the test will not truly reflect the real effects of asphalt plant mixing and transportation.

5. Notes

When testing binders with the roller method a wire hook (paper clip) can be used to support the roller over the open treatment bottle. This encourages complete drainage of the binder back into the bottle.

- 5.1 The preparation of the oven shall be in accordance with ASTM: D2872 but adapted using the apparatus shown in Figure 1.

- 5.2 When the quantitative value of the loss or gain in mass is required use two separate treatment bottles for the determination. Cool the containers for the test to room temperature and weigh each treatment separately to the nearest 0,001g. Proceed as per 3.2. At the conclusion of the testing period remove the treatment bottles from the oven. Cool the treatment bottles to room temperature in a desiccator. Weigh to the nearest 0,001g and calculate the loss on the basis of the binder in the bottle. Discard the residue.

References:

ASTM: D2072

Austrroads MBT 03

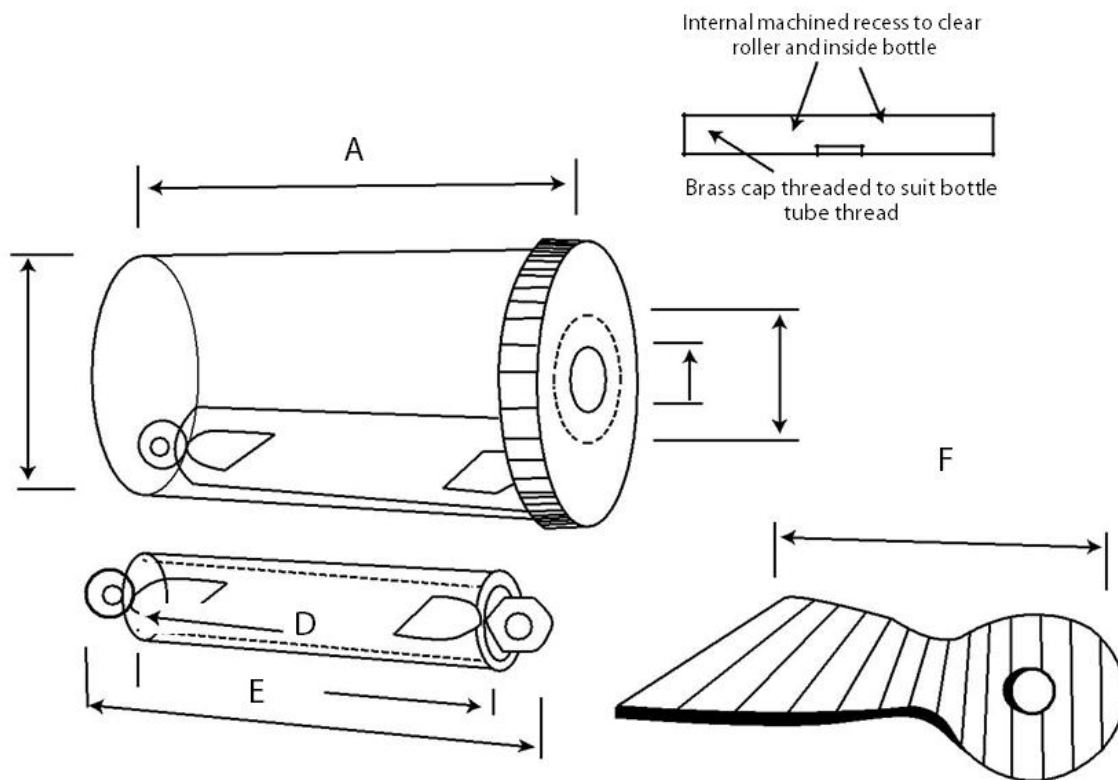

Figure 1: Metal treatment bottles and rollers

A	Brass tube (length) Closed at base with 1,6 mm brass plate External thread to match cap at top	140 ± 1 mm
B	Nominal (2.5 inch Φ) 1,6 mm wall	63 ± 1 mm
C	Air hole in screw cap (diameter)	12 ± 0.5 mm
C1	Internal recess approximately 3 mm deep	30 ± 1 mm
D	20 mm Φ standard brass threaded tube	120 ± 1 mm
E	Length of roller including ends	$138 (\pm) - 1$ mm
F	Length of 1,6 mm brass end pieces With 90° left hand twist from end of roller	40 ± 2 mm

METHOD MB-4: ELASTIC RECOVERY OF POLYMER

MODIFIED BINDERS BY DUCTILOMETER

1. Scope

This test method is used for the characterisation of the elastic properties of a polymer modified bituminous binder.

Duplicate samples are extended under pre-determined conditions for a distance of 200 mm and the elongated thread is cut. After a recovery period of one hour the extent of the recovery of the thread is determined.

2. Apparatus

2.1 Specimen composite moulds

Two composite moulds as specified in Figure 1 shall be used to form the specimens. The moulds consists of a base plate made of a non-corrosive metal, fitted with a clamping device, and of four frame pieces made of a copper-zinc alloy (brass), as shown in Figure 2. The four frame pieces consist of two side-pieces and of two end-pieces, known as clips, in each of which a hole is bored for attachment to the stay bolt plates of the testing machine. The boreholes in the clips shall be so designed that they fit easily, but without play, onto the stay bolts.

2.2 Ductilometer

The Ductilometer consists of a trough as specified in sub-clause 2.2.1 in conjunction with a testing machine as specified in sub-clause 2.2.2, and a measuring instrument as specified in sub-clause 2.2.3. The ductilometer shall be designed so as to ensure vibration-free testing.

2.2.1 Trough

The trough shall permit an elongation of the briquette specimens to a length of at least 100 cm. Its dimensions shall be such that at least two specimens may be tested side by side. The clearance between the moulds containing the briquette specimens and the sidewalls of the trough shall be not less than 10 mm. When the trough is two-thirds full, the bath liquid shall cover the moulds, attached to the testing machine, both above and below by at least 25 mm. An opal glass sheet shall be placed over the bottom of the trough.

Maintenance of the temperature limits specified in sub-clause 3.3 shall be ensured by circulating the bath liquid through the connected thermostat (see sub clause 2.3), and if necessary by the provision of additional insulation.

While the specimens are being pulled apart, the circulation of the bath shall not be switched off, but its rate of flow shall be reduced to such an extent that the threads are not visibly affected by the flow of the liquid. When a moving deflector is fitted at the water inlet point, experience has shown that a rate of water circulation of up to 1.5 litres per minute may be permitted.

2.2.2 Testing machine

The testing machine shall be capable of pulling apart two specimens simultaneously. The specimens shall be held by two plates made of non-corrosive metal fitted with stay bolts (see Figure 3). At least one of these plates shall be movable in the direction of pull. The diameter of the stay bolts shall be $8 \pm 0,1$ mm. The drive of the testing machine shall be so designed that the stay bolts may be pulled apart at a uniform speed of $50 \text{ mm/min} \pm 2,5 \text{ mm/min}$ throughout the test. The specified speed shall, in particular, be maintained, even when high deformation resistance has to be overcome at the start of the test. Periodic checks shall be made, under load, to establish whether the testing machine can maintain the specified pulling speed.



Note:

It will be found useful to use mechanical step-down gearing to permit the selection of other, lower speeds, such as 20, 10 or 5 mm/min.

A stop shall be provided to ensure that in the initial position of the testing machine the distance between the boreholes in the clips exactly corresponds to that between the stay bolts.

2.2.3 Measuring instrument

The scale interval of the measuring instrument for determining the distance of elongation shall not be greater than 5 mm.

2.3 Thermostat

The thermostat controlling the temperature in the trough of the ductilometer and in the water bath (see sub-clause 2.5) must be capable of keeping temperatures constant within $\pm 0,2^{\circ}\text{C}$.

2.4 Thermometer

DIN 12775 – E 0,1/0/50 thermometer.

2.5 Water bath

The water bath for preheating the briquette specimens shall have a capacity of not less than 10 litres capacity, and a filling height of not less than 70 mm. It shall contain a perforated shelf, supported in a position 25 mm above the bottom of the bath. The water bath shall be so dimensioned that when the briquette specimens, locked to their base plates, are placed on the perforated shelf, they shall be at least 10 mm apart and at a distance of at least 10 mm from the side walls of the bath. The water bath shall be filled to a level where the surface of the briquette specimens is covered by bath liquid to a depth of at least 25 mm. The trough (see sub-clause 2.2.1) may also be used for preheating the specimens.

2.6 Knife

The knife shall have a straight cutting edge of at least 40 mm in length, or a planing blade.

2.7 Mould release agent

For example, a mixture of equal parts of glycerin and dextrin.

2.8 Bath liquid

Bath liquid for filling the water bath as specified in sub-clause 2.5 and the trough as specified in sub-clause 2.2.1. The water shall be free of surface-active additives.

If differences between the specific gravity of the water and the density of the specimen material disturbs the formation of the thread, causing it either to rise to the surface or sink to the bottom of the bath, then the specific gravity of the bath liquid in the trough shall be adjusted to the density of the specimen material by the addition of either methyl alcohol or sodium chloride.

3. Test specimen preparation

The samples, taken according to the method given in MB-1 and MB-2, shall be prepared as described in DIN 52003. The test shall be carried out using two specimens, each weighing approximately 20 g.

3.1 Preparation of the composite moulds

The base plate and the wedge-shaped surfaces of the sidepieces of each mould shall be lightly coated with a mould release agent, such as that specified in sub-clause 2.7. Then the frame pieces of the mould shall be assembled on the base plate as shown in Figure 2, the clamping device being used to lock the frame pieces rigidly to the base plate, forming a tight seal at all points of contact. A check shall be made that the distance between the sidepieces of the adjacent moulds is $10 \pm 0,1$ mm.

3.2 Filling the two composite moulds

The two moulds, slightly heated if necessary, shall be filled, care being taken to avoid the formation of bubbles, by pouring the molten sample until the meniscus rises noticeably above the level of each mould. Particular attention shall be paid when filling the moulds that the right-angled edges between base plate and frame pieces are entirely filled, the same applying to the undercuts in the clips.

3.3 Heat treatment of briquette specimens

After filling, the moulds shall initially be left, protected against dust, for 30 minutes to cool to room temperature, then transferred to the water bath maintained at the test temperature to within $\pm 0,2^{\circ}\text{C}$. The clearances between the briquette specimens and to the sidewalls, as specified in sub-clause 2.5, shall be checked, as well as the depth of immersion of the specimens in the bath fluid.

The moulds containing the briquette specimens shall first be kept for 30 minutes in the water bath. Then the excess binder shall be cut off level with the mould frame with the aid of a warmed knife. The moulds shall then be returned immediately to the water bath, maintained at the test temperature, and kept there for a further 85 - 95 minutes.

Between filling the moulds and starting the elongation operation in the ductilometer, 150 ± 10 minutes shall have elapsed.

4. Test procedure

After the specified heat treatment, the briquette specimens shall be lifted off the base plate and transferred to the ductilometer trough, where the clips shall be mounted on the stay bolts of the testing machine which has been brought into

the initial position for the test. The scale of the testing machine shall previously have been adjusted to the zero setting. Then the sidepieces shall be carefully removed. Circulation of the bath liquid shall now be reduced, being set either at or below the maximum permissible rate of flow specified. Throughout the test, the temperature shall not vary from the initial temperature by more than 0,3°C.

The testing machine specified in sub-clause 2.2.2 shall now be actuated. The threads formed by the two briquette specimens, as they are pulled apart, shall be observed and the appearance of clumps (pearling) shall be reported.

Threads shall be suspended at a level about halfway between the surface of the liquid and the bottom of the trough. If the threads rise to the surface to sink to the bottom, the specific gravity of the bath liquid shall be corrected as described in sub-clause 2.8, and the test repeated.

The samples shall be elongated to a distance of 200 mm. After the elongation distance of 200 mm has been reached, stop the ductilometer and hold the sample in its elongated position for five minutes. After five minutes, clip the sample approximately in half by means of scissors or other suitable cutting device. Let the sample remain undisturbed in the ductilometer for a one-hour recovery period. At the end of this time, retract the half sample specimen until the two broken ends touch. At this point note the elongation in mm.

5. Calculations and report

Calculate the percent recovery by the following formula:

$$\% \text{ Recovery} = \frac{200 - E}{200}$$

Where

E represents the observed elongation after re-joining of the sample.

Report the percent recovery to the nearest whole percentage point. Repeat the test if the duplicate test results differ by more than two percentage points.

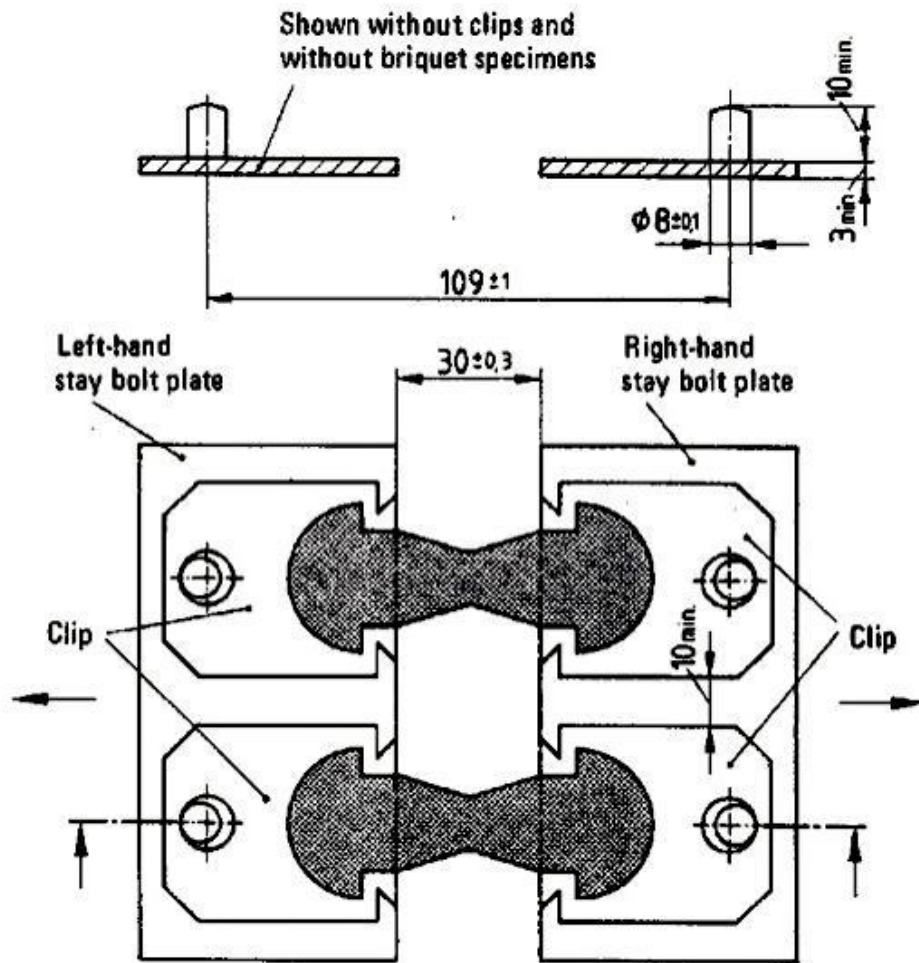

Figure 3 - Stay bolt plates of the testing machine, with two briquette specimens, in the initial position

METHOD MB-6: STORAGE STABILITY OF POLYMER MODIFIED BINDERS

1. Scope

This test method sets out the procedures for the determination of the stability of a modified binder. The Softening Points (ring & ball) are determined of the upper and lower sections of a sample stored vertically for three days.

Definition

Stability is the resistance to segregation between the modifying agent and the base bitumen when the modified binder is stored hot.

2. Apparatus

- 2.1 An open ended 300 mm long glass tube with a diameter of 12,5 mm;
- 2.2 Silicon rubber stoppers (capable of withstanding temperatures of 185°C) to seal a 12,5 mm diameter tube;
- 2.3 An oven, thermostatically controlled to maintain a temperature of 180°C ± 2°C;
- 2.4 A stand with a clamp that will hold the glass tube vertically in the oven;
- 2.5 A glass cutter;
- 2.6 Ring and ball apparatus according to method ASTM D36.

3. Method

3.1 Preparation of test sample

Refer to MB-2 for preparation of the sample before testing.¹

Pour the melted sample into the pre-heated glass tube (after corking the base) to about 10 mm from the top. Cork the top of the glass tube. Ensure that the cork has a v-notch cut along its length to act as a breather. Place the glass tube in the oven (set at 180°C ± 2°C) in a vertical position (using the standard clamp). The sample must remain in the oven for three days at 180°C ± 2°C. After three days remove the glass tube and allow it to cool to room temperature. The sample must then be cooled to about 0°C. At this temperature cut the tube with a glass cutter transversely into three equal sections.

Prepare the top and bottom sections in accordance with method ASTM D36 (ring & ball) to determine the softening points of the top and bottom respectively.

4. Calculations

Calculate the difference in softening point between the top and bottom sections and record in °C.

Note

¹ It is important that the specified 180°C is used in order for dissociation to take place – if not the two networks have not been broken down.

METHOD MB-8: PULL OUT TEST METHOD FOR SURFACING AGGREGATE

1. Scope

This method sets out the procedure for the determination of the pull out test for surfacing aggregates.

Definition

The pull out load test is the load required to dislodge a stone chip from a bituminous seal on the road to assess when the surface treatment can be opened to traffic.

2. Apparatus

- 2.1 A spring balance with a capacity of 1000g and graduated every 10g;
- 2.2 Crocodile clips or small spring loaded battery clamps with attached nylon or string approximately 0,6 m long;
- 2.3 A 1m long strip of neoprene sponge rubber, 20 mm wide and 3 mm thick;
- 2.4 One tube of high strength flexible "Pratley wonder-fix";
- 2.5 One tube of "Pattex" super gel;
- 2.6 One pair of scissors;
- 2.7 A contact thermometer reading 80°C in 0,2°C increments.

3. Preparation of apparatus

Attach crocodile clips to each end of a suitable length of nylon line. Attach one end to the spring balance. The length of line should be such that the zero point of the scale is at eye level. Place an average sized stone into the crocodile clip and zero spring balance. Complete this test method as per **Section 4**.

4. Test method

Select an area of the road surface in either the left or right wheel path of the surfacing. Measure and record the surface temperature to the nearest 0,5°C using the contact thermometer. The thermometer should be placed against several stones in the vicinity of the test and an average taken.

Record the start times of the test and temperatures. Select a stone and attach the crocodile clip to the stone. Slowly raise the upper portion of the scale and apply a pull out rate of 20g per second. Monitor the scale carefully and continue the load increments until the stone becomes detached.

Record the maximum reading on the pull-out test data sheet (Figure 1). Remove the stone from the clip and repeat the test a further nine times at this position. If the stone twists during the test and results in a significantly reduced pull out force, the result should be ignored.

5. Calculations

Apply a temperature correction factor to the data to give pull out loads at 40°C or such other temperature in the range of 15°C to 50°C as may be expected on the road. The following formula and preliminary constants for various binders should be used:

$$f_2 = f_1 \cdot 10^m \times (T_2 - T_1)$$

Where:

f_2 = pull out force (gram @ temp T_2 (°C))

f_1 = pull out force (gram) @ temp T_1 (°C)

m = constant = 0,050 for conventional binders

= 0,033 for polymer modified binders

= 0,025 for bitumen rubber

At temperatures below 15°C the binder becomes more brittle and the above corrections no longer apply.

Calculate the mean and standard deviation of the temperature corrected data. The mean value of 1 standard deviation approximates the 10th percentile value. Depending on the traffic volumes and speeds, and the consequences of stripping, the 15th percentile value or 10th percentile value should be used to assess whether the road could be opened to traffic.

Data table for pull-out test for surfacing aggregate

Pull out test for surfacing aggregate		
Location:		Date:
Seal placed:	Time:	Date: Application:
Binder type:		
Stone size:	ALD:	
Comments on stone loss:		
Test number		
	Time	Road temperature
Start		
End		
Stone number	Pull-out load (g)	Stone dimensions (mm)
1		
2		
3		
4		
5		
6		
7		
8		
9		
10		

6. Criteria

Preliminary criteria for opening to traffic are tabulated in the table below.

Geometry	Traffic volume (vpd)	Minimum likely pull out force taking temperature changes into account
Summer: temperatures generally >15°C		
Straight	<4000	100
	>4000	150
Curves 200 - 800m	<4000	200
	>4000	250
Sharp Curves and intersections		300
Winter: Temperatures can drop to < 5°C		
Straight	<4000	200
	>4000	250
Curves 200 - 800m	<4000	250
	>4000	300
Sharp Curves and intersections		350

METHOD MB-10: BALL PENETRATION AND RESILIENCE OF BITUMEN-RUBBER BLENDS

1. Scope

This test method sets out the procedures for the determination of the penetration of a standard ball into non-aged and oven-aged bitumen rubber as well as the rebound recovery.

Definition

The penetration of bitumen is defined as the distance in tenths of a millimetre that a standard needle will penetrate into the bitumen under fixed conditions of loading, time and temperature. This test measures the relative hardness or consistency of bitumen rubber blends.

2. Apparatus

- 2.1 A standard bitumen penetrometer with a plunger assembly which can be tared to weigh $75g \pm 0,01$ when the ball penetration tool is attached;
- 2.2 A ball penetration tool with a ball of $17 \pm 0,1$ mm in diameter attached to a shaft, which fits into the penetrometer. The tool should weigh $27,5g (\pm 0,1g)$ (see Figure 1);
- 2.3 Glass beakers, diameter of approximately 70 mm and at least 70 mm deep or flat bottom metal tins with
- 2.4 A water bath, thermostatically controlled, capable of maintaining a temperature of $25 \pm 2^\circ\text{C}$;
- 2.5 A penetration transfer dish of glass or heavy plastic with a diameter of at least 130 mm and at least 120 mm high.

3. Method

3.1 Preparation of test specimen

Take samples of bitumen rubber (MB-1) and prepare them as described in method MB-2. Fill the test container in paragraph 2.3 to a height of approximately 60 mm with the bitumen rubber.

Leave the sample to stand under laboratory atmospheric conditions ($24^\circ\text{C} \pm 4^\circ\text{C}$) for $24\text{hrs} \pm 2$ hrs. Then place the sample in a water bath at $25^\circ\text{C} \pm 2^\circ\text{C}$ for at least two hours before testing.

3.2 Testing

Coat the penetration ball, fitted to the penetrometer, very lightly with silicone grease. Place the container with sample in the transfer dish filled with water from the water bath to cover the surface of the sample to a depth of at least 20 mm.

Place the ball in contact with the surface of the material to be tested, not less than 10 mm from the side of the container. Set the indicator dial of the penetrometer to zero. Release the penetration assembly and allow it to penetrate the specimen for five seconds. Record the reading as ball penetration "P" in tenths of a mm.

Without returning the dial pointer to zero, press the ball down an additional 100 units at a rate of 10 units per second. Re-engage the clutch to hold the tool down for an additional five seconds. During this time set the dial pointer on zero for non-spring load spindles. Release the clutch, allow the specimens to recover for 20 seconds, engage the clutch and record the reading as F (see point 4).

Determine the penetration and resilience, if possible, at three points equally spaced from one other, and at least 10 mm away from the side of the container. Between each test, determine the temperature of the water in the transfer dish. If the temperature has dropped by more than 1°C , replace the water from the water bath.

4. Calculations

Calculate the resilience for each test to the nearest one percent as follows:

$$\text{Resilience (\%)} = P + 100 - F$$

Where:

P = Ball penetration value (0,1 mm)

F = reading after recovery (0,1 mm)

Report the average ball penetration value and average resilience for the conditioned and unconditioned samples to the nearest one percent.

5. Notes

- 5.1 If the mass of the ball penetration tool is 27,5g, it should only be necessary to remove the 50g weight from the penetration shaft used for the normal bitumen penetration test in order for the assembly to have a total mass of 75g.
- 5.2 Where metal tins are used as sample containers, the rims of the tins should not be much above the level of the sample for the material at the start of the test. If the container is seamed around its bottom rim, a suitable spacer should be placed under it to ensure a solid base. A plaster of Paris spacer, made as follows, has been found to work well. Mix plaster of Paris to a pasty consistency. Flatten the paste with a straight edge to approximately 5 mm thick. Coat the bottom of a metal container lightly with silicone grease and press it slowly into the plaster of Paris (to assist in the removal of air under the tin.) Cut the excess plaster of Paris at the sides of the tin, and leave the plaster of Paris at the sides of the tin to form a neat base. Leave the plaster of Paris to set and remove the tin. This base can remain in the transfer dish. Tins are placed on it for testing.
- 5.3 The clutch of the penetrometer may slip slightly during the rest period when testing material with a fairly high resilience. Holding the measuring plunger down and monitoring any slippage on the dial may prevent this. Slippage can be corrected or prevented by slight downward pressure on the plunger.

References:

SABITA method BR2T

ASTM Designation D3407 and D3408

EN1426

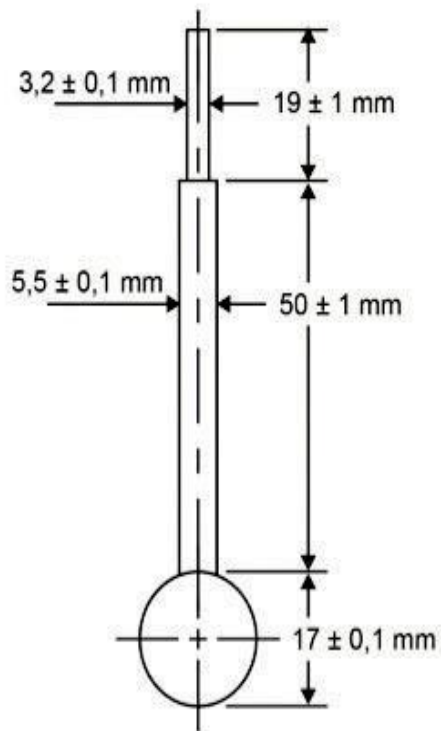

Material steel mass of ball
penetration tool: $27,5 \pm 0,1g$

Total mass of ball and
penetrometer shaft: $75 \pm 0,1g$

NOTE:

ONLY THE FOLLOWING

DIMENSIONS ARE CRITICAL:

Top diameter of shaft: $3,2 \pm 0,1$ mm

Diameter of ball: $17 \pm 0,1$ mm

Mass of tool: $27,5 \pm 0,1g$

Figure 1: Ball penetration tool

METHOD MB-11: COMPRESSION RECOVERY OF BITUMEN RUBBER BINDERS

1. Scope

The elastic recovery of a bitumen-rubber cylinder is measured after it has been compressed to half its original height.

Definition

Compression recovery of bitumen-rubber blends indicates a measure of the contribution made by the rubber crumbs.

2. Apparatus

- 2.1 A compression frame capable of reducing the height of the bitumen- rubber specimen from 25,4 mm to 12,7mm (fixed). The frame shall have a removable metal base plate on which the specimen(s) can be formed (see Figure 1);
- 2.2 Moulds of silicone rubber or other suitable material capable of withstanding a temperature of 175°C with inside dimensions: height 25,4 mm; diameter 19,0 mm. The moulds should be made in such a way that they can be easily removed (see 4.1);
- 2.3 A water bath or air cabinet capable of maintaining a temperature of 25°C ± 0,2°C;
- 2.4 Releasing agent such as a 1:1 mixture of glycerine and dextrin or silicone grease;
- 2.5 A height-measuring device such as a T gauge to measure to an accuracy of at least 0,5 mm;
- 2.6 Self-releasing or plastic coated paper discs of 20 mm diameter (see 5.2);
- 2.7 A stop watch.

3. Method

3.1 Preparation of test cylinders

Prepare the bitumen-rubber as described in Method MB-2. Place two cylindrical moulds on the clean base plate, each approximately halfway between the centre of the base plate and the guide holes. If moulds other than silicone rubber are used they should be treated with the releasing agent. Fill the moulds to excess with the bitumen-rubber. Allow cooling to room temperature and remove the excess material with a hot spatula.

3.2 Testing

Immerse the test specimens together with the base plate in the water bath or air cabinet at 25°C ± 2°C for at least one hour. Remove it from the water bath or air cabinet and carefully remove the moulds from the cylinders. It is important not to pull the sample off. Place the base plate in the test rig.

Place a round of paper on top of each bitumen-rubber cylinder. Place the compression plate on top and, by means of the lever, compress the bitumen-rubber cylinders with a smooth quick action until the spacer rings touch the compression plate, while keeping the compression plate as level as possible. Do not hold the lever down for an extended period of time, i.e. not more than 1 SECOND, as this may significantly affect the test result.

Immediately remove the compression plate and the releasing paper rounds and note the time accurate to five seconds. If a stopwatch or other timing device is used, set it in operation.

Measure the height of each of the cylinders after the following time intervals: 5 minutes ± 5 seconds, 1 hour ± 5 minutes, 4 hrs ± 10 minutes and 24 hours ± 30 minutes recovery. During this time samples should be left where they cannot be damaged, and will be free from vibrations and shock.

4. Calculations

Calculate and report the percentage recovery as a percentage of the original height to the nearest one percent after five minutes, 1 hour, 4 hours and 4 days recovery:

$$\% \text{ Recovery} = \frac{h \times 100}{25.4}$$

Where: h = height of recovered specimen in mm.

Report the results accurate to 0,1% for five minutes, one hour, four hours and four days recovery.

Notes

Silicone rubber moulds may be made using a self-curing or two-part silicone rubber compound or similar material. Metal moulds can be used to make the silicone rubber moulds. The silicone rubber mould is cut vertically on one side to facilitate removal of the bitumen-rubber cylinder. It is held together with an elastic band when in use.

The backing paper used for self-stick labels or film has been found to work well.

If an air cabinet is not available the samples may be kept in a room where the temperature is controlled at $25^{\circ}\text{C} \pm 2^{\circ}\text{C}$. This fact should be mentioned in the test report.

Reference:

Sabita Method BR₃T

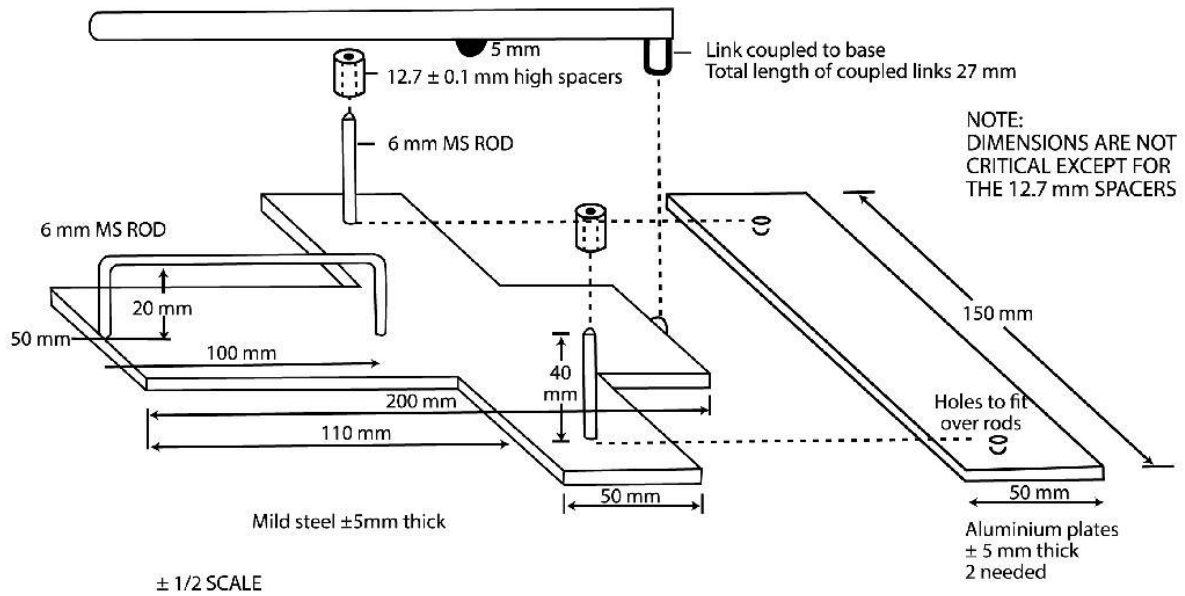

Figure 1: Apparatus for compression recovery test

METHOD MB-12: FLOW TEST FOR BITUMEN-RUBBER BINDERS

1. Scope

This test measures the flow properties of bitumen-rubber blends at high temperatures.

2. Apparatus

- 2.1 Moulds consisting of a brass or copper plate 3,2 mm thick with a cut out rectangle 20 x 60 mm. Multiple specimen moulds can also be used with the cut-outs not less than 20 mm apart;
- 2.2 Smooth, flat, tinned oven trays or similar stiff metal plates at least 200 x 200 mm (see 5.1);
- 2.3 A force draft drying oven capable of maintain a temperature of $60^{\circ}\text{C} \pm 1^{\circ}\text{C}$, free from vibration (see 5.2);
- 2.4 A water bath or air cabinet capable of maintaining a temperature of $25^{\circ}\text{C} \pm 1^{\circ}\text{C}$, and big enough to accommodate the tray in 2.2;
- 2.5 A firm frame or support to keep the tray (2.2) at an angle of $35^{\circ} \pm 2^{\circ}$ in the oven;
- 2.6 A scale or other measuring instrument to measure accurately to 1 mm;
- 2.7 A spatula with a 25 mm wide blade;
- 2.8 Water-soluble releasing agent such as a 1.1 mixture of dextrin and glycerine or silicone grease.

3. Method

3.1 Preparation of test specimen

Prepare the bitumen rubber as described in method MB-2. Prepare at least two moulds for each sample to be tested by coating it thoroughly with the releasing agent. Place the moulds not less than 20 mm apart with one short side approximately 10 mm from one side of the tray. (Multiple specimen moulds can also be used – see 2.1). This will be the topside of the specimens. Fill the moulds with an excess of bitumen rubber.

When cool, after 30 minutes, trim the top surface level with the sides of the moulds using a hot spatula. Holding the flat side of the blade of the spatula at an angle to the specimen, level off the excess material. It should not be scraped off with the sharp edge of the blade. The slight bulge that is formed behind the spatula is acceptable.

Remove the moulds carefully from the specimens after cooling and wash clean the test specimens and plate clean of releasing agent. Make a mark opposite and in line with the bottom end of each of the specimens on the bottom of the tray with an indelible heat resistant pen or soft pencil. Place the tray with specimens in a water bath or air cabinet at $25^{\circ}\text{C} \pm 1^{\circ}\text{C}$ for 30 ± 5 minutes prior to testing.

3.2 Testing

Remove the tray from the water bath or air cabinet and dry it and the specimens with an absorbent cloth or paper towel. Place the tray in the oven at $60^{\circ}\text{C} \pm 1^{\circ}\text{C}$ at an angle of $35^{\circ} \pm 2$ degrees with the topside facing up. The oven should not vibrate as this may influence the results. Leave the specimens in the oven for four hours \pm five minutes, remove and allow cooling to room temperature. Make a mark opposite the lower end of the specimen below the previous mark. Measure the distance between the two marks as the flow distance accurately to 1 mm.

4. Calculations

Report the flow distance in mm accurately to 1 mm for the average of the two samples. Also indicate in the report if any separation of bitumen from the bitumen-rubber is noticed.

5. Notes

- 5.1 Research indicates that the metal from which the tray is made does not influence the results. The only important prerequisite is that the surface should be smooth and free from scratches, and it is thus important that the tray is not scratched during cleaning;
- 5.2 It may be impossible to find a force draft oven without any internal vibration. Every effort should be made to reduce and minimise vibration in the oven as far as possible, since this may influence the results.

Reference:

Sabita Method BR 5 T

METHOD MB-13: DYNAMIC VISCOSITY OF BITUMEN-RUBBER BINDERS

1. Scope

This method describes the determination of the dynamic viscosity of bitumen-rubber blends using a hand held, battery operated, and rotary viscometer.

2. Apparatus

- 2.1 A hand-held rotary viscometer with a rotor-cup to measure dynamic viscosity in the range of 0,5 to 10 Pa.s. For laboratory use the instrument should be mountable on a stand (see also 5.2);
- 2.2 A purpose-made stand or retort stand and clamps to hold the viscometer rigidly for viscosity determinations in the laboratory;
- 2.3 An oven thermostatically controlled and capable of maintaining temperatures of 150°C to 300°C accurate to $\pm 5^\circ\text{C}$;
- 2.4 A 300°C thermometer accurate to $\pm 1^\circ\text{C}$;
- 2.5 Asbestos gloves;
- 2.6 A stirring rod or spatula capable of mixing and stirring of the viscous bitumen material;
- 2.7 Metal tins or glass beakers with capacities of approximately one litre and with a diameter of at least 100 mm, allowing a sample depth of at least 80 mm. If the tins are also used as sample containers, they should have tightly fitting lids.

3. Method

3.1 In the field

Take a representative sample of bitumen-rubber blend as described in Method MB-2, using the sample containers in 2.7 above. Directly after taking the sample, stir it well with a suitable stirring rod. Measure and record the temperature (see 5.1).

Attach the correct viscosity cup-rotor to the viscometer such that viscosity measurements will be between 0,5 and 10 Pa.s (see 5.2). Ensure that the vent hole on top of the rotor is open. Place the sampling tin or beaker on a firm non-heat absorbing base and immerse the viscometer rotor in the centre of the sample up to the depth mark on the stem. After approximately 30 seconds start the rotation of the rotor while holding the instrument absolutely horizontal (see 5.3). If possible, a stand should be used. Take and record the viscosity reading to an accuracy of 0,1 Pa.s approximately ten seconds after the rotor is set in motion. Remove and clean the rotor (see 5.6).

3.2 In the laboratory

Take a representative sample of the bitumen-rubber blend as described in Method MB-1.

Heat the sample as quickly as possible in an oven to the recommended spray temperature (see 5.5). If the sample is in a container as specified in 2.7 above, the viscosity can be determined directly. Otherwise, transfer the sample to a container as specified in 2.7. Stir the sample with a suitable stirrer while the temperature is monitored. When the required test temperature is reached (see 5.4), remove the stirrer and thermometer and determine the viscosity as described in 3.1. The viscometer should be fixed onto a stand to hold it firm and horizontal. Remove and clean the rotor (see 5.6).

4. Calculations

The viscosity readings should be taken and recorded accurately to 0,1 Pa.s. Report the results to the same accuracy together with the date, time, sampling and binder temperature (see 5.6).

5. Notes

- 5.1 In seal work it is necessary to measure the viscosity of the bitumen-rubber blend before, during and after spraying to determine its spray ability. To make the results meaningful the viscosity and temperature should be determined as soon as possible after sampling to prevent heat loss;
- 5.2 The metric standard for expressing dynamic viscosity is Pa.s. Most viscometers are, however, calibrated in either centipoise (cP) or dPa.s with $1\text{ cP} = 1\text{ dPa.s} \times 10^{-2} = 1\text{ Pa.s} \times 10^{-3}$.

Thus, $1,5\text{ Pa.s} = 15\text{ dPa.s} = 1500\text{ cP}$;

- 5.3 To prevent damage to the instrument some manufacturers stipulate that the viscometer be set in motion before the cup is immersed. To comply with these requirements, while still allowing for the cup to heat up to the temperature of the bitumen-rubber, it is suggested that the cup be immersed for 30 seconds, pulled more than halfway out of the binder, the motion started and the cup immersed to the mark. The viscosity reading should then be taken approximately 10 seconds after this

second immersion;

- 5.4 The viscosity should be measured at the spraying temperature;
- 5.5 The bitumen-rubber sample should be heated and tested in the shortest time possible, as the properties of the blend may change considerably with prolonged heating. Material should be discarded if it has remained at this high temperature for more than one hour, unless time dependent tests are required;
- 5.6 Clean the rotor-cup as soon as possible after the test, while it is still hot, by first wiping excess material off with a dry cloth or paper and then cleaning it in a suitable organic solvent such as toluene.

Reference:

Sabita Method BR5T

METHOD MB-14: PARTICLE SIZE DISTRIBUTION AND LOOSE FIBRE CONTENT OF RUBBER CRUMBS

1. Scope

This method describes the procedure for a dry sieve analysis for rubber crumbs intended for use in bitumen-rubber blends. The loose fibres are collected during the sieving operation as a rough indicator of fibre content.

2. Apparatus

- 2.1 The following test sieves, 200 mm diameter, complying with SANS 3310-1: 2 mm; 1 mm; 0,600 mm; 0,300 mm; 0,150 mm; 0,075 mm with a lid and receiver;
- 2.2 A suitable nylon or bristle sieve brush;
- 2.3 A balance accurate to 0,01g to weigh up to at least 200g.

3. Method

Obtain a representative sample of approximately 500g of rubber crumbs, either from randomly selected individual bags as delivered on site or from the rubber crumbs container at the blending or mixing plant, at random intervals.

Mix the sample thoroughly and break down any lumps that it may contain (see Notes 5.3). Scoop out duplicate test samples of more or less 100g each and test each sample as follows:

- Nest the sieves on the receiver in descending order of size and transfer the sample to the top sieve. Place the lid in position and hand sieve the sample for approximately two minutes by rocking and tapping the sieves. Mechanical sieving can be used for this initial operation, especially when the presence of fibres is suspected, but the final sieving should be done by hand;
- Remove the lid and gently rub the rubber crumbs in the uppermost sieve. Hand sieve the material until nothing more passes that specific sieve. If fibre is present it can be clearly seen in the sample as short light coloured hairs, which will form a ball during the sieving operation. Collect the fibre balls carefully and place them in a clean receptacle. Remove the sieve and repeat the operation for each sieve in the series. For the 1,18 mm and other finer sieves, the fibres collected on a specific sieve are placed back on the next coarser sieve and re-sieved to remove rubber particles sticking to the fibres. The fibres are then carefully collected and placed in the fibre receptacle (see Notes 5.2);
- Weigh the material retained on each sieve accurately to 0,01 g. Also determine the mass of the fibres collected from the sieves.

4. Calculations

Calculate the percentages passing the sieves as described in SANS 3001-AG1 and report the results to the nearest 0,1%.

Calculate the fibre content as a percentage of the total sample by mass and report together with the grading results. In the report the following should be noted:

- The batch number and sampling date if available;
- The condition of the bags in which the rubber was stored;
- The height of the rubber bag stockpile;
- The presence of foreign materials in the rubber such as steel wire, string etc.;
- If the rubber crumbs are loose or lumpy;
- If fibre particles are visible or not.

4. Notes

- 5.1 Although the fibre particles in rubber crumbs are fairly short they tend to form a ball during the sieving operation. The same happens during the blending and/or mixing operation and their presence creates construction problems and may lead to an unacceptable end product;

It is impossible to separate or collect all the fibres in the crumbs, but usually the specifications state that no fibre or a very small percentage is allowable. This method will therefore be sufficient in most instances where fibre could be a problem.

- 5.2 The sieving operation and collection of fibres is a tedious process and care should be taken that the operator does not hurry the test;
- 5.3 Rubber crumbs should be dry when sampled. If damp, they should be dried in a force drying oven at 60°C for one hour prior to testing. Higher temperatures and prolonged heating may change the characteristics of the rubber and should be avoided.

Reference:

Sabita Method BR6T

METHOD MB-16: Bulk density of rubber crumbs

1. Scope

This test determines the bulk density in water of rubber crumbs in the particle size range 0,600 to 0,300 mm used in bitumen rubber manufacture. The method in MB-15 (5.2) can be used as a quick test but this method will be regarded as the referee method.

2. Apparatus

- 2.1 The following test sieves, 200 mm in diameter, complying with the requirement of SABS 197: 0,300 mm and 0,600 mm and a receiver.
- 2.2 A balance to weigh up to at least 50 g accurate to 0,01 g
- 2.3 A glass-measuring cylinder, at least class B, of 100ml capacity with 1 ml graduations.
- 2.4 A glass beaker with a capacity of 250ml with graduations not greater than 50ml apart.
- 2.5 Glass stirring rods of lengths suitable for use in the glass beaker and measuring cylinder
- 2.6 A wash bottle with jet.
- 2.7 A hotplate, thermostatically controlled, capable of gently boiling a beaker of water
 - 2.8 An anionic wetting solution such as a 10% Teepol solution.

3. Method

3.1 Preparation of samples

Obtain a bulk sample of the rubber at least 1 kg mass by taking small sub-samples from at least 10 randomly selected bags of rubber crumbs. Thoroughly mix the crumbs and pour out into a large pan or similar container. Using a small scoop, such as a teaspoon, scoop out small quantities of rubber crumbs randomly to obtain a test sample of 20-25 g. If the sample is wet, air-dry it. Prepare at least two samples.

3.2 Sieving of material

Clean and dry the test sieves to be used. Stack the two sieves on a receiving pan. Add the test sample to the 0,600mm sieve and hand sieve it for approximately two minutes by rocking and tapping the sieves. Check whether the mass of material retained on the 0,300 mm sieve exceeds 20 g. If it does, divide the material in two and receive one half for at least another two minutes on the 0,300 mm sieve. If there is less than 7,5g of material on the 0,300 mm sieve prepare and sieve a second lot of material as described above. After sieving mix the two lots thoroughly. Treat the duplicate sample similarly.

3.3 Determination of the bulk density

Transfer $7,5 \pm 0,1g$ of the material retained on the 0,300 mm sieve to a clean dry 250 ml beaker. Add 70 ml of distilled or de-ionised water and bring it to boil on the hotplate. Allow boiling for 30 minutes while stirring occasionally with a stirring rod. Wash particles deposited on the wall of the beaker down with water from the wash bottle. Keep the total volume of material in the beaker between 60 and 70 ml.

After the 30-minute period, transfer the contents of the beaker to a 100 ml measuring cylinder using the wash bottle to wash it in. Make the volume in the measuring cylinder up to 100 ml.

Add 10 ml of the prepared wetting agent and thoroughly agitate the contents by stirring rapidly in a circular motion. Reverse the direction of stirring to stop rotation of the suspension and allow it to remain undisturbed for 15 minutes

After the 15 minutes, measure the settled volume of the rubber particles to the nearest 0,5 ml, neglecting any floating particles. Similarly test the duplicate sample.

4. Calculations

Calculate the bulk density of each test sample as follows:

$$\text{Bulk density (kg/m)} = \frac{7.5 \times 1000}{V}$$

Where V = settled volume of the rubber particles (ml)

Calculate the average bulk density for the two samples. If the results differ by more than four percent (repeatability) another sample should be tested and the result, differing by more than four percent from any one of the others, rejected.

References:

OLIVER J.W.H. A bulk density test to characterize the morphology of rubber particles. ARRB Internal Report, AIR 286-3
Australian Road Research Board, April 1981

Sabita Method BR8T

METHOD MB-17: SOFTENING POINT OF MODIFIED BITUMEN BY RING AND BALL METHOD

1. Definition

The softening point is the temperature at which the modified bitumen attains a particular degree of softness under the specified conditions of the test.

Reference:

ASTM D36 (using shouldered ring)

METHOD MB-18: DYNAMIC (APPARENT) VISCOSITY OF POLYMER MODIFIED BINDERS

1. Scope

This test method outlines the procedure for measuring the apparent viscosity of a bitumen binder at the specified test conditions using the Brookfield Thermocel system and SC 27 or 21 spindles.

2. Definition

The co-efficient of viscosity is the ratio between applied shear stress and rate of shear. This co-efficient, stated in Pa.s, measures the resistance to flow of a liquid, and is commonly termed viscosity.

Reference:

ASTM D4402

METHOD MB-20: RECOVERY OF RESIDUE OF MODIFIED BITUMEN EMULSION

- a. The recovery of modified bitumen residue from emulsion using a rotary evaporator (**Method A**);
- b. The recovery of modified bitumen residue from emulsion using a Bunsen burner (**Method B**).

1. Scope

This method describes the recovery of modified bitumen residue from a modified bitumen emulsion containing some fluxing oil. The residue recovered represents the modified binder on the road after a period in which the fluxing oils are allowed to evaporate.

METHOD A

2. Apparatus

- 2.1 A rotary evaporator, including holding and receiving flasks, designed to be subjected to at least one atmosphere of vacuum (about 63 cm Hg), according to DIN 1996 (Buchi or similar);
- 2.2 A vacuum pump and manometer (Hg);
- 2.3 An oil bath and heating facility;
- 2.4 A thermometer measuring 0 - 200°C.

3. Sample preparation

Polymer modified binder samples for testing shall be prepared in accordance with method MB 1 and method MB 2.

- 3.1 Add 300g ±1g modified emulsion to the one litre holding flask of the rotary evaporator (500g ±2g in two litre flask). Attach firmly to the apparatus and lower the flask into the oil bath at 60°C ±5°C. (See Figure 1). The oil should come up to the level of emulsion in the flask. Start rotation of the flask at 50 rpm and subject to a vacuum of 30 cm Hg ±5 cm. Start the flow of cold water through the condenser of the apparatus. Leave for 60 minutes ±5 minutes. Raise the temperature gradually to 150°C, ensuring that the emulsion does not boil over onto the condenser (vacuum as before). This may take up to 30 minutes. Leave at 150°C ±5°C for 60 minutes ±5 minutes.

While the vacuum is maintained during recovery, a small flow of air should be introduced into the holding flask (via the valve at the top of the condenser) to assist in driving off the volatiles (water and flux).

Remove the holding flask containing recovered modified bitumen and pour out for further testing.

METHOD B

4. Apparatus

- 4.1 A Bunsen burner;
- 4.2 A one litre squat glass or metal beaker;
- 4.3 A glass thermometer measuring 0°C - 200°C.

5. Sample preparation as per 3.1

- 5.1 Add approximately 160g of modified emulsion to the beaker. Place on the heating facility (See Figure 2). Stir the sample with the thermometer at approximately two revolutions per second. Continue stirring until the temperature of the residue is 170°C. Maintain the temperature of the residue at between 170°C and 180°C for a further 15 minutes, while stirring continuously. The heating rate should be such that the preparation is completed within 45 minutes.

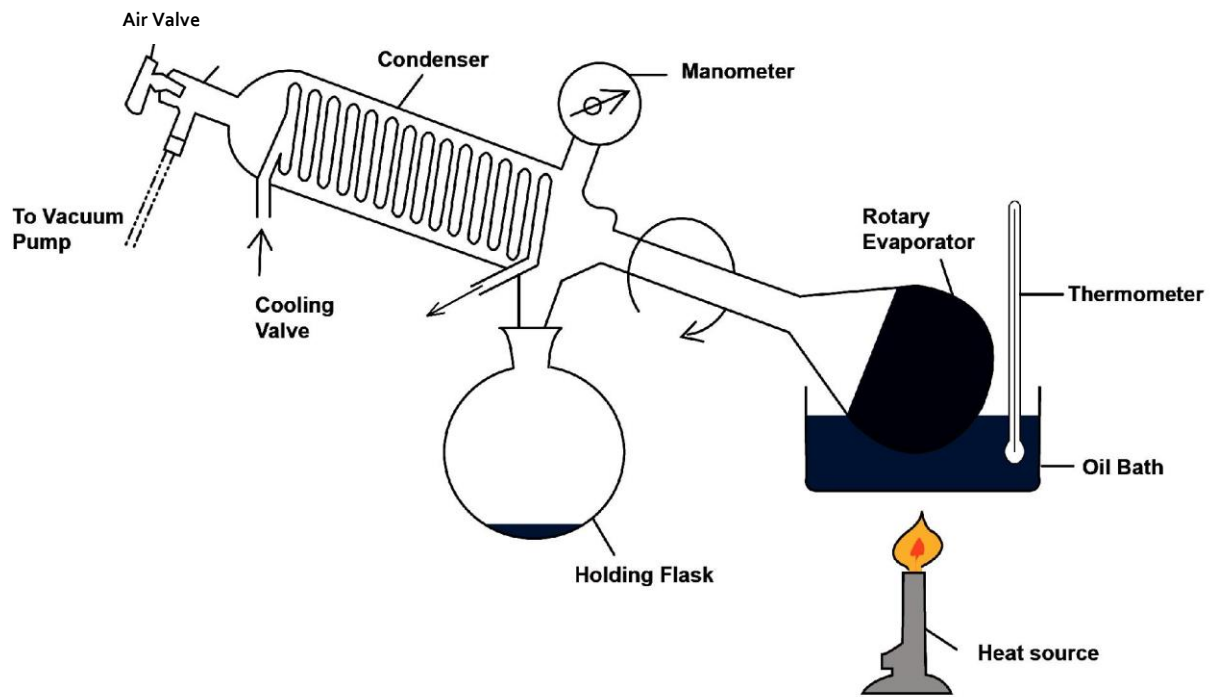

Figure 1: Preparation of polymer modified binder samples

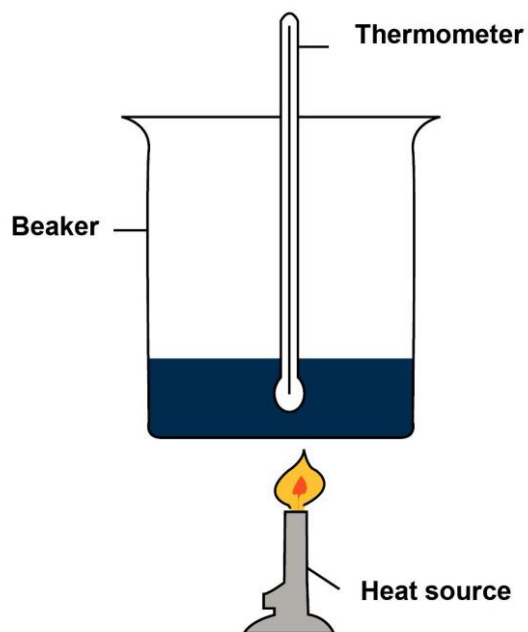

Figure 2: Sample preparation as per 3.1

METHOD MB-21: VISCOSITY OF MODIFIED BITUMEN EMULSIONS BY MEANS OF THE SAYBOLT-FUROL VISCOMETER

1. Scope

The Saybolt Furol viscosity is determined by measuring the efflux time, in seconds, of 60 ml of sample flowing through a calibrated Furol orifice under the specified conditions of the test.

Reference:

SANS 4001 BT₄ which refers to ASTM: D244

METHOD MB-22: WATER CONTENT OF MODIFIED BITUMEN EMULSIONS

1. Scope

This method describes the procedure for determination of the water content of a bitumen emulsion by distillation and using a carrier liquid.

Reference:

ASTM: D244

METHOD MB-23: RESIDUE ON SIEVING OF A MODIFIED BITUMEN EMULSION

1. Scope

This method determines the quantity of modified binder present in an emulsion in particles of such size as to be retained on a gauge of specified mesh opening.

2. Method

SANS 4001 BT₄, which refers to I.P. 91, with the following amendments:

- The two test sieves should be a 0,150 mm sieve, 50 mm high and approximately 80 mm in diameter as well as a 0,710 mm sieve, 50 mm high and approximately 80 mm in diameter;
- The reagent (soap solution) shall be a 0,1N hydrochloric acid solution containing 1% cetyltrimethyl- ammonium bromide (centrimide).

References:

Cationic: SANS 4001 BT₄, which refers to IP 91

Anionic: SANS 4001 BT₃, which refers to IP 91

METHOD MB-24: PARTICLE CHARGE OF MODIFIED BITUMEN EMULSIONS

1. Scope

This test determines the mass of binder deposited on a cathode after being subjected to the particle charge test for 30 minutes.

2. Method

- The ASTM D 244 method is followed with the following amendment;
- The thickness of the electrode shall be 0,71 mm.

Reference:

SANS 4001 BT₄ which refers to ASTM D 244